

ONLINE AGENDA INFORMATION

The online Agenda is not the official Agenda for the El Cajon City Council, but is posted and published five days prior to the City Council Meeting for the convenience of the public. Changes may be made up to 72 hours prior to the meeting; therefore added or deleted items may not appear on the City's website at this time. The City Council's official Agenda is prepared and posted outside City Council Chambers in the kiosk 72 hours prior to every regular meeting, and 24 hours prior to every special meeting. You may call the City Clerk's Office at (619) 441-1763 for information about any changes to this Agenda.

AGENDA BINDER, INCLUDING AGENDA REPORTS, IS AVAILABLE FOR VIEWING AFTER 4:00 P.M., THE FRIDAY BEFORE THE COUNCIL MEETING, AT THE EL CAJON BRANCH OF THE PUBLIC LIBRARY, 201 E. DOUGLAS AVENUE, PHONE (619) 588-3718.

LIBRARY HOURS: Monday – Thursday 9:30 a.m. – 8:00 p.m., Friday & Saturday 9:30 a.m. – 5:00 p.m., and Sunday 12:00 – 5:00 p.m.

SUPPLEMENTAL AGENDA ITEM DOCUMENTS AND/OR MATERIALS RECEIVED AFTER POSTING OF THIS AGENDA, IF ANY, MAY BE VIEWED IN THE CITY CLERK'S OFFICE AT 200 CIVIC CENTER WAY, EL CAJON, MONDAY THROUGH THURSDAY, 7:30 A.M. TO 5:30 P.M. AND ON ALTERNATE FRIDAYS FROM 8:00 A.M. TO 5:00 P.M.

FOR A SCHEDULE OF FRIDAY CITY HALL CLOSURES, VISIT WWW.CITYOFELCAJON.US OR CALL THE CITY CLERK'S OFFICE AT (619) 441-1763.

CITY OF EL CAJON

*City Council/Housing Authority/
Successor Agency to the Redevelopment Agency*

AGENDA



February 13, 2018

**Honoring
and celebrating
the people
who make
El Cajon**

***The Valley
of
Opportunity***

Bill Wells
Mayor

Gary Kendrick
Mayor Pro Tem

Steve Goble
Councilmember

Ben Kalasho
Councilmember

Bob McClellan
Councilmember

Douglas Williford
City Manager

Morgan Foley
City Attorney

Graham Mitchell
Assistant City Manager

Angela Aguirre
City Clerk



**February 13, 2018
3:00 p.m.**

The Agenda contains a brief general description of each item to be considered and most items have a *RECOMMENDATION* from Staff or a Commission, which Council will consider when making a final decision.

Copies of written documentation relating to each item of business on the Agenda are on file in the City Clerk's Office and in the Agenda Book next to the podium in the Council Chambers.

PLEASE COMPLETE A "REQUEST TO SPEAK" FORM FOR EACH ITEM PRIOR TO THE COMMENCEMENT OF THE MEETING AND SUBMIT IT TO THE CITY CLERK if you wish to speak about an Item on the Agenda or under Public Comment.

- **CALL TO ORDER:** Mayor Bill Wells
- **ROLL CALL:** City Clerk Angela Aguirre



PLEDGE OF ALLEGIANCE TO FLAG AND MOMENT OF SILENCE

- **POSTINGS:** The City Clerk posted Orders of Adjournment of the January 23, 2018, Meeting and the Agenda of the February 13, 2018, Meetings in accordance to State Law and Council/Authority/Successor Agency to the Redevelopment Agency Policy.
- **PRESENTATIONS:**
 - El Cajon Teen Coalition
 - Fletcher Hills Recreation Center - Award
- **AGENDA CHANGES:**

CONSENT ITEMS: (1.1 – 1.8)

** Asterisk indicates agenda item includes back up information available for review.*

Consent Items are routine matters enacted by one motion according to the RECOMMENDATION listed below. With the concurrence of the City Council, a Council Member or person in attendance may request discussion of a *Consent Item* at this time.

***1.1 MINUTES OF CITY COUNCIL/HOUSING AUTHORITY/SUCCESSOR AGENCY TO THE EL CAJON REDEVELOPMENT AGENCY MEETINGS**

RECOMMENDATION: That the City Council/Housing Authority/Successor Agency to the El Cajon Redevelopment Agency approves Minutes of the January 23, 2018 Meeting of the El Cajon City Council/Housing Authority/Successor Agency to the El Cajon Redevelopment Agency.

1.2 WARRANTS

RECOMMENDATION: That the City Council approves payment of Warrants as submitted by the Finance Department.

1.3 APPROVAL OF READING BY TITLE AND WAIVER OF READING IN FULL OF ORDINANCES ON AGENDA

RECOMMENDATION: That the City Council approves the reading by title and waive the reading in full of all Ordinances on the Agenda.

***1.4 RESOLUTIONS: APPROVAL OF PLANS AND SPECIFICATION FOR STREET RESURFACING/PAVEMENT PRESERVATION 2018, JOB NO. PW3622, BID NO. 029-18 (Report: Dirk Epperson, Director of Public Works)**

RECOMMENDATION: That the City Council adopts the next RESOLUTIONS in order to:

- Approve Plans and Specifications for Street Resurfacing Pavement Preservation 2018, PW3622, Bid No. 029-18; and
- Direct a Notice Inviting Sealed Bids to be opened on March 15, 2018.

CONSENT ITEMS: (Continued)

- *1.5 RESOLUTION: AWARD OF BID NO. 026-18 – BMW POLICE MOTORCYCLE (Report: Nahid Razi, Purchasing Agent)**

RECOMMENDATION: That the City Council adopts the next RESOLUTION in order awarding the bid to the sole responsive, responsible bidder, Powersports Unlimited, Inc., dba: BMW Motorcycles of Escondido, in the amount of \$26,767.86.

- *1.6 FIRST AMENDMENT TO FY 2017-18 ONE YEAR ACTION PLAN FOR RE-ALLOCATION OF AVAILABLE CDBG FUNDS (Report: Anthony Shute, Director of Community Development)**

RECOMMENDATION: That the City Council:

- Re-allocates \$76,200.00 in available unallocated Community Development Block Grant (CDBG) funds to Project PK3582/C0923, Stoney's Neighborhood Park Improvements; and
- Appropriates \$76,200.00 of CDBG funding to Parks Capital Improvement Project PK3582 Stoney's Neighborhood Park Improvements.

- *1.7 APPROVE CONTRACT CHANGE ORDER FOR PW3575 ADA PEDESTRIAN CURB RAMP AND SIDEWALKS 2017 PROJECT, BID NO. 018-18 (Report: Yazmin Arellano, Deputy Director of Public Works/City Engineer)**

RECOMMENDATION: That the City Council approves the Contract Change Order for PW3575 ADA Pedestrian Curb Ramp and Sidewalks 2017 Project, Bid No. 018-18, in the amount of \$60,603.50 for Crest Equipment, Inc., for construction and installation of ADA pedestrian curb ramps and related concrete surface improvements. The existing contract amount with Crest Equipment, Inc., is \$213,699.35, and the revised contract amount, if approved, would be \$274,302.85.

- *1.8 COMMUNITY EVENT IN THE RIGHT-OF-WAY - RunEC (Report: Frank Carson, Director of Recreation)**

RECOMMENDATION: That the City Council approves the use of the public right-of-way for the RunEC St. Patrick's Day Half Marathon/5K.

PUBLIC COMMENT

At this time, any person may address a matter within the jurisdiction of the City Council/Housing Authority/Successor Agency to the El Cajon Redevelopment Agency that is not on the Agenda. Comments relating to items on today's agenda are to be taken at the time the item is heard. State law prohibits discussion or action on items not on the Agenda; however, Council, Authority and Agency Members may briefly respond to statements or questions. An item may be placed on a future Agenda.

2. WRITTEN COMMUNICATIONS: None

3. PUBLIC HEARINGS: None

4. ADMINISTRATIVE REPORTS:

***4.1 RESOLUTION: AWARD OF BID NO. 021-18, SEWER AND STORM DRAIN REPAIR AND REPLACEMENT, WW3519 (Report: Nahid Razi, Purchasing Agent)**

RECOMMENDATION: That the City Council adopts the next RESOLUTION in order awarding the bid to the sole responsive, responsible bidder, Burtech Pipeline, Inc., in the amount of \$2,627,759.00 for the base bid and Additive Alternate No. 3.

5. COMMISSION REPORTS: None

6. ACTIVITIES REPORTS OF MAYOR WELLS/COMMENTS

SANDAG (San Diego Association of Governments); League of California Cities, San Diego Division; Heartland Fire Training JPA – Alternate; Indian Gaming Local Community Benefit Committee. LAFCO*

***6.1 COUNCIL ACTIVITIES REPORT/COMMENTS**

6.2 LEGISLATIVE REPORT – No Report

ACTIVITIES REPORTS OF COUNCILMEMBERS

7. MAYOR PRO TEM GARY KENDRICK

Heartland Communications JPA; Heartland Fire Training JPA.

*7.1 COUNCIL ACTIVITIES REPORT/COMMENTS

8. COUNCILMEMBER BOB MCCLELLAN

MTS (Metropolitan Transit System Board); Harry Griffen Park Joint Steering Committee; Heartland Communications JPA – Alternate.

*8.1 COUNCIL ACTIVITIES REPORT/COMMENTS

9. COUNCILMEMBER BEN KALASHO

East County Economic Development Council – Alternate; METRO Commission/Wastewater JPA; Indian Gaming Local Community Benefit Committee – Alternate.

*9.1 COUNCIL ACTIVITIES REPORT/COMMENTS

*9.2 PROCLAMATION HONORING THE EL CAJON POLICE DEPARTMENT

RECOMMENDATION: That the City Council place on its next agenda a proclamation honoring our Police Department for its outstanding service to the community.

10. COUNCILMEMBER STEVE GOBLE

SANDAG – Alternate; SANDAG Public Safety Committee – Alternate; Chamber of Commerce – Government Affairs; MTS (Metropolitan Transit System Board) – Alternate; East County Economic Development Council; METRO Commission/Wastewater JPA - Alternate.

*10.1 COUNCIL ACTIVITIES REPORT/COMMENTS

*10.2 ENHANCEMENTS TO THE CITY'S EFFORT ADDRESSING HOMELESSNESS

RECOMMENDATION: That the City Council place on a future meeting agenda a discussion, and any relevant action, on the ways to make the public, including people experiencing homelessness, more aware of the help available to people who are homeless, including the City's own efforts.

11. **JOINT COUNCILMEMBER REPORTS: None**
12. **GENERAL INFORMATION ITEMS FOR DISCUSSION**
13. **ORDINANCES: FIRST READING - None**
14. **ORDINANCES: SECOND READING AND ADOPTION - None**
15. **CLOSED SESSIONS: None**

ADJOURNMENT: The Regular Joint Meeting of the El Cajon City Council/ El Cajon Housing Authority/Successor Agency to the El Cajon Redevelopment Agency held this 13th day of February 2018, is adjourned to Tuesday, February 13, 2018, at 7:00 p.m.

GENERAL INFORMATION:

The following item(s) are informational and are not discussed unless the Council/Authority brings the items forward for discussion under Item No. 12 of the agenda.

- *A. TEEN COALITION STATUS REPORT
(Report: Frank Carson, Director of Recreation)**

RECOMMENDATION: That the City Council receives and files the information-only Teen Coalition status report.

*Joint Meeting
El Cajon City Council/Housing
Authority/Successor Agency to the El Cajon
Redevelopment Agency*

Tuesday, February 13, 2018
7:00 p.m.

COUNCIL CHAMBERS
200 Civic Center Way
El Cajon, California

AGENDA

- **CALL TO ORDER:** Mayor Bill Wells
- **ROLL CALL:** City Clerk Angela Aguirre

PLEDGE OF ALLEGIANCE TO FLAG AND MOMENT OF SILENCE

- **AGENDA CHANGES:**
- **PUBLIC COMMENT:**

At this time, any person may address a matter within the jurisdiction of the City Council/Housing Authority/Successor Agency to the El Cajon Redevelopment Agency that is not on the Agenda. Comments relating to items on today's docket are to be taken at the time the item is heard. State law prohibits discussion or action on items not on the Agenda; however, Council, Authority and Agency Members may briefly respond to statements or questions. An item may be placed on a future Agenda.

** Asterisk indicates agenda item includes back up information available for review.*

PUBLIC HEARINGS:

***100 INTERVIEWS FOR COMMISSION VACANCIES (Report: Angela Aguirre, City Clerk)**

RECOMMENDATION: That the City Council

- *Conducts interviews for one (1) seat on the Personnel Commission and one (1) seat on the Planning Commission, and appoints applicants to serve appropriate terms;*
- *Continues to accept applications for an available seat on the Veterans' Commission until filled, as no applications were received.*

Personnel Commission Applicant:

1. Richard Nasif (Incumbent)

Planning Commission Applicants:

1. Zachary Bunshaft
2. Humbert Cabrera
3. Pavel Consuegra
4. Vickie Fageol
5. Sherri Johnston
6. Robert Pennoyer
7. James Queenan
8. Janet Reaume
9. Anthony Sottile (Incumbent)

ADJOURNMENT: The Adjourned Regular Joint Meeting of the El Cajon City Council/El Cajon Housing Authority/Successor Agency to the El Cajon Redevelopment Agency held this 13th day of February 2018, is adjourned to Tuesday, February 27, 2018, at 3:00 p.m.



Upcoming Events in El Cajon City Council Meeting for February 13, 2018



City Council Interviews Applicants for City Commissions - February 13, 7 p.m.

The City Council will be interviewing applicants for open commission seats on the Personnel Commission, Planning Commission and Veterans' Commission. Applicants will be interviewed during the 7:00 p.m. City Council Meeting. Call (619) 441-1763 for additional information.

Happy Valentine's Day! - Wednesday, February 14

City offices will be closed in observance of the Presidents' Day holiday – Monday, February 19

City Hall Closed on Alternate Fridays - Next closure on Friday, February 23

For a full calendar of City Hall office hours, visit www.cityofelcajon.us.

City Council Meeting – Tuesday, February 27, 3 p.m. and 7 p.m. (as needed)

Meetings are held on the second and fourth Tuesday of the month as needed in the Council Chamber, at 200 Civic Center Way. For information, and to view the full agenda, visit www.cityofelcajon.us.

Daylight Saving Time Begins - Sunday, March 11

It's time to "spring forward" and turn clocks ahead one hour at 2:00 a.m. Sunday morning. It's also a great opportunity to check and replace the batteries in your smoke and carbon monoxide (CO) alarms in your home and/or business. Visit www.heartlandfire.org for more safety tips!

Upcoming Community Events:

RUN EC's St. Patrick's Day Half Marathon - Sunday, March 4, 6:15 a.m.

Register now for the St. Patrick's Day Half Marathon, 5K Run/Walk, Green Mile, and Tribes & Clans competition. The Half Marathon begins at 198 West Main Street, in Downtown El Cajon, next to the El Cajon Arch. Funds raised will benefit several East County charities. Visit www.stpatricksdlayhalf.com for more information, to register or to volunteer. Hosted by the Run East County Foundation.

Arbor Day Celebration - Saturday, March 24, 8 a.m.

Join the City of El Cajon as it celebrates the 21st year of receiving the Tree City USA award and the 29th Annual Arbor Day ceremony. Kennedy Park, 1675 E. Madison Avenue. To volunteer, please call (619) 441-1658.

Save the date: 5th Annual America on Main Street - Saturday, May 19, 2 p.m. to 9 p.m.

This free community event celebrates Diversity in America with live entertainment, rides, crafts and food! A Naturalization Ceremony is at 1:30 p.m. For details, visit www.AmericaOnMainStreet.org.

El Cajon Recreation Guide Winter 2018 - now available!

The City offers a wide variety of classes and sports for every member of the family! Register for recreation programs in person at the City recreation centers or online at www.elcajonrec.org. For information, call (619) 441-1754.

Stay Informed on City Events, Services & Meetings - Visit the City of El Cajon's website at www.cityofelcajon.us. Register for the "E-NOTIFICATION."

JOINT MEETING OF THE EL CAJON CITY COUNCIL/HOUSING AUTHORITY/SUCCESSOR AGENCY TO THE REDEVELOPMENT AGENCY

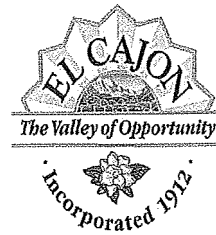

MINUTES

CITY OF EL CAJON EL CAJON, CALIFORNIA

January 23, 2018

An Adjourned Regular Joint Meeting of the El Cajon City Council/Housing Authority/Successor Agency to the Redevelopment Agency of the City of El Cajon, California held Tuesday, January 23, 2018, was called to order by Mayor/Chair Bill Wells at 3:00 p.m., in the Council Chambers, 200 Civic Center Way, El Cajon, California.

ROLL CALL

Council/Agencymembers present:	Goble, Kalasho and McClellan
Council/Agencymembers absent:	None
Mayor Pro Tem/Vice Chair present:	Kendrick
Mayor/Chair present:	Wells
Other Officers present:	Aguirre, City Clerk/Secretary Foley, City Attorney/General Counsel Mitchell, Assistant City Manager Williford, City Manager/Executive Director

Mayor Wells invited Chamber of Commerce, CEO, Eric Lund to lead the PLEDGE OF ALLEGIANCE TO FLAG and MOMENT OF SILENCE. (The Courts have concluded that sectarian prayer as part of City Council Meetings is not permitted under the Constitution).

Mayor Wells dedicated the Council meeting to the Late Chuck Hansen.

POSTINGS: The City Clerk posted Orders of Adjournment of the January 9, 2018, meeting and the Agenda of the January 23, 2018, meeting in accordance with State Law and Council/Authority/Successor Agency to the Redevelopment Agency Policy.

PRESENTATIONS:

- **Commendation: Jim Lynch, Director of Administrative Services**
- **Commendation: In Memory of Mr. Chuck Hansen**
- **Employee Service Awards**

Last Name	First Name	Years	Position
Smith	Greg	5	G.I.S. Technician
Watson	Kristen S.	5	Police Dispatcher
Carter	Michael	10	Paramedic Firefighter
Cavicchioni	Holly	10	Sr. Engineering Technician
Celiceo	Andrew	10	Facilities Technician
Jaboro	Christine	10	Assistant Engineer
Kelsen	Jacob	10	Paramedic Firefighter
Laatsch	Robert	10	Fire Captain
Oslovar	John	10	Paramedic Firefighter
Stanley	Brandon	10	Police Officer
Taylor	Jeffery	10	Code Compliance Officer
Taylor	Jeff	10	Police Officer
Thorn	William	10	Fire Engineer
Arana	Eduardo	15	Park Maintenance Worker
Cutting	Jake	15	Police Sergeant
Doyle	Michael	15	Police Sergeant
Martinez	Max	15	Public Works Equipment Operator
Paz	Heather	15	Police Services Officer
Wilson	Edmund	15	Public Works Equipment Operator
Chasin	Mike	20	Fire Division Chief
Hamma	Thomas	20	Fire Captain
Hemphill	James	20	Fire Captain
Jepsen	Patricia	20	Utility Worker
Palombo	Paul	20	Equipment Mechanic
Miller	Walter	30	Police Lieutenant

AGENDA CHANGES: None

CONSENT ITEMS: (1.1 – 1.8)

MOTION BY McCLELLAN SECOND BY KENDRICK, to APPROVE Consent Items 1.1 to 1.8.

MOTION CARRIED BY UNANIMOUS VOTE.

1.1 MINUTES OF CITY COUNCIL/HOUSING AUTHORITY/SUCCESSOR AGENCY TO THE EL CAJON REDEVELOPMENT AGENCY

Approve Minutes of the January 9, 2018 Meeting of the El Cajon City Council/Housing Authority/Successor Agency to the El Cajon Redevelopment Agency.

1.2 WARRANTS

Approve payment of Warrants as submitted by the Finance Department.

1.3 APPROVAL OF READING BY TITLE AND WAIVER OF READING IN FULL OF ORDINANCES ON AGENDA

Approve the reading by title and waive the reading in full of all Ordinances on the Agenda.

1.4 RESOLUTION: EAST COUNTY PERFORMING ARTS CENTER ARCHITECT AGREEMENT (Report: Graham Mitchell, Assistant City Manager)

Adopts RESOLUTION NO. 003-18 approving an Agreement for Professional Services with Rios Clementi Hale Studios to provide architectural services for the renovation of the East County Performing Arts Center (ECPAC) in the not-to-exceed amount of \$495,000.00, not including unanticipated studies or ancillary expenses.

Remainder of page intentionally left blank.

CONSENT ITEMS: (Continued)

1.5 RESOLUTION: AWARD OF BID NO. 017-18, 2018 MOTOR VEHICLES (Report: Nahid Razi, Purchasing Agent)

- Finds the first low bidder non-responsive to Line Items 19 through 23;
- Finds the second low bidder non-responsive to Line Items 11 through 18; and
- Adopts RESOLUTION NO. 004-18 awarding the bid to the lowest responsive, responsible bidders: Theodore Robins Ford for Line Items 1-5, 11-15, 37-41 in the amount of \$196,101.64; Raceway Ford, Inc., for Line Items 19-36 in the amount of \$164,497.78; and Sunroad Auto, LLC dba Kearny Pearson Ford for Line Items 6-10, 16-18 in the amount of \$167,976.67, for a total amount of \$528,576.09.

1.6 2017 SAN DIEGO COUNTY LAW ENFORCEMENT FOUNDATION GRANT (Report: Jeff Davis, Chief of Police)

- Authorize the City Manager or designee to accept the 2017 San Diego County Law Enforcement Foundation Grant in the amount of \$2,036.50, and to execute any grant documents and agreements necessary for the receipt and use of these funds; and
- Appropriate funds in the amount of \$2,036.50 to purchase (5) Avon Voice Projection Units (VPU) for the Police Department's tactical units to be used during deployments when the Department's Avon Gas Masks are needed.

1.7 SUPPORT OF 2018 MISS EL CAJON SCHOLARSHIP PROGRAM (Report: Graham Mitchell, Assistant City Manager)

Designates \$1,500.00 from the City Council Contingency Budget for the Miss El Cajon Scholarship Program.

1.8 REQUEST FOR TIME EXTENSION OF TENTATIVE PARCEL MAP (TPM) 658; 1196 BROCKTON STREET, ENGINEERING JOB NO. 3626. (Report: Dirk Epperson, Director of Public Works)

Grants a one-year time extension for TPM 658 and sets the new expiration date to be February 23, 2019, in accordance with Municipal Code Section 16.12.110.

PUBLIC COMMENT:

Jim Cirigliano spoke about rent stabilization, he requested Council support with rent control.

Bonnie Price spoke about the importance of a properly conducted census.

Zack Bunshaft, applicant for the Planning Commission, stated he will not be available the day of the interview. He introduced himself to Council, and answered a few questions.

Brenda Hammond spoke about the benefits of dance therapy.

Kevin Miller thanked the City Council for their continued support on the homeless problem. He introduced Stacy Mackey, Chairman of the Board for the Chamber of Commerce who is part of the Homeless Task Force. He spoke of the many services available to the homeless community.

Michelle Krug requested more help for the homeless population.

Shane Parmely, representing Break the Ban, shared her concern for the gay homeless community. She stated the faith based groups may turn them away.

Brenda Arnold, representing Break the Ban, asked for more support from Council for the homeless community.

Stephanie Harper stated the amount of money spent on city vehicles could have been used for other issues, such as the homeless problem.

Mayor Wells and **Councilmember McClellan** invited the students in the audience to introduce themselves to Council.

2. **WRITTEN COMMUNICATIONS: None**

3. **PUBLIC HEARINGS: None**

4. **ADMINISTRATIVE REPORTS: None**

5. **COMMISSION REPORTS: None**

6. ACTIVITIES REPORTS OF MAYOR WELLS/COMMENTS

SANDAG (San Diego Association of Governments); League of California Cities, San Diego Division; Heartland Fire Training JPA – Alternate; Indian Gaming Local Community Benefit Committee. LAFCO*

6.1 Council Activities Report/Comments

REPORT AS STATED.

6.2 LEGISLATIVE REPORT - No Report

6.3 COUNCIL ASSIGNMENTS

RECOMMENDATION: That the City Council consider and approve council assignments to the various boards and commissions giving El Cajon input on matters important to this region as follows:

Mayor Bill Wells: SANDAG (San Diego Association of Governments); League of California Cities, San Diego Division; Heartland Fire Training JPA – Alternate; Indian Gaming Local Community Benefit Committee. LAFCO*

*Elected to the LAFCO Commission for a four year term to represent the east county, by east county Mayors, in December, 2017.

Mayor Pro Tem Gary Kendrick: Heartland Communications JPA; Heartland Fire Training JPA.

Councilmember Steve Goble: SANDAG – Alternate; SANDAG Public Safety Committee – Alternate; Chamber of Commerce – Government Affairs; MTS (Metropolitan Transit System Board) – Alternate; East County Economic Development Council; METRO Commission/Wastewater JPA - Alternate.

Councilmember Ben Kalasho: East County Economic Development Council – Alternate; METRO Commission/Wastewater JPA; Indian Gaming Local Community Benefit Committee – Alternate.

Councilmember Bob McClellan: MTS (Metropolitan Transit System Board); Harry Griffen Park Joint Steering Committee; Heartland Communications JPA – Alternate.

COUNCIL ASSIGNMENTS: (Continued)

MOTION BY McCLELLAN SECOND BY KENDRICK, to APPROVE council assignments to the various boards and commissions giving El Cajon input on matters important to this region as presented.

**MOTION CARRIED BY A 4 - 1 VOTE
(Kalasho – No).**

ACTIVITIES REPORTS OF COUNCILMEMBERS

7.

MAYOR PRO TEM GARY KENDRICK

Heartland Communications JPA; Heartland Fire Training JPA.

7.1 Council Activities Report/Comments

REPORT AS STATED.

8.

COUNCILMEMBER BOB McCLELLAN

MTS (Metropolitan Transit System Board); Harry Griffen Park Joint Steering Committee; Heartland Communications JPA – Alternate.

8.1 Council Activities Report/Comments

REPORT AS STATED.

9.

COUNCILMEMBER BEN KALASHO

East County Economic Development Council – Alternate; METRO Commission/Wastewater JPA; Indian Gaming Local Community Benefit Committee – Alternate.

9.1 Council Activities Report/Comments

REPORT AS STATED.

ACTIVITIES REPORTS OF COUNCILMEMBERS: (Continued)

9.2 PROPOSED RESOLUTION TO END URGENCY ORDINANCE PROHIBITING FOOD SHARING EVENTS ON PUBLIC PROPERTY

RECOMMENDATION: That the City Council agendaize for February 13, 2018 City Council meeting, a RESOLUTION formally ending the Urgency Ordinance, subject to the County of San Diego ending State of Emergency regarding Hepatitis A.

DISCUSSION

Item 9.2 is withdrawn as the County of San Diego declared the end to Hepatitis A emergency.

Councilmember Kalasho praised the El Cajon Police Department (ECPD) for the way they handled the public outbreaks in regards to the Urgency Ordinance on food sharing. He recommends that a proclamation be awarded to the ECPD.

Mayor Pro Tem Kendrick stated that during the San Diego County Board of Supervisors Meeting, **Supervisor Ron Roberts**, complimented **Mayor Wells** for his leadership in handling the Hepatitis A emergency situation in El Cajon.

10. COUNCILMEMBER STEVE GOBLE

SANDAG – Alternate; SANDAG Public Safety Committee – Alternate; Chamber of Commerce – Government Affairs; MTS (Metropolitan Transit System Board) – Alternate; East County Economic Development Council; METRO Commission/Wastewater JPA - Alternate.

10.1 Council Activities Report/Comments

REPORT AS STATED.

11. JOINT COUNCILMEMBER REPORTS: None

12. GENERAL INFORMATION ITEMS FOR DISCUSSION: None

13. ORDINANCES: FIRST READING - None

14. ORDINANCES: SECOND READING AND ADOPTION - None

Councilmember Kalasho shared a video of "El Cajon Elves", a program geared towards seniors in the City of El Cajon.

15. CLOSED SESSION:

RECOMMENDATION: That the City Council/Housing Authority/Successor Agency to the El Cajon Redevelopment Agency adjourns to Closed Session as follows:

15.1 CONFERENCE WITH LEGAL COUNSEL - EXISTING LITIGATION - Pursuant to paragraph (1) of subdivision (d) of Government Code Section 54956.9:

Name of Case: El Cajon Residents for Responsible Governance

v.

City of El Cajon, et al.

San Diego Superior Court

Case No. 37-2017-00045604-CU-WM-CTL

Councilmember Kalasho disqualified himself due to the fact that a member of El Cajon Residents for Responsible Governance attended a Chamber Business meeting of which his wife acts as CEO.

16. RECONVENE TO OPEN SESSION AT 4:30 P.M.

City Attorney Foley reported the following actions:

15.1 No Action taken.

Adjournment: Mayor Wells adjourned the Adjourned Regular Joint Meeting of the City Council/Housing Authority/Successor Agency to the Redevelopment Agency held this 23rd day of January 2018, at 4:31 p.m. to Tuesday, February 13, 2018, at 3:00 p.m.

Angela Aguirre
City Clerk/Secretary

**APPROVAL OF READING BY TITLE AND WAIVER OF READING
OF ORDINANCES ON THIS AGENDA**

The City Council waives the reading of the full text of every ordinance contained in this agenda and approves the reading of the ordinance title only.

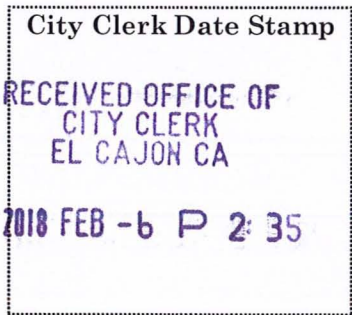

City of El Cajon Agenda Report

MEETING: Feb. 13, 2018

ITEM NO: 1.4



TO: Mayor Wells, Mayor Pro Tem Kendrick,
Councilmembers Goble, Kalasho and McClellan

FROM: Dirk Epperson, Director of Public Works

SUBJECT: Approval of Plans and Specifications for Street Resurfacing/Pavement Preservation 2018, Job No. PW 3622, Bid No. 029-18

RECOMMENDATION: That the City Council adopts the next RESOLUTIONS in order to:

1. Approve Plans and Specifications for Street Resurfacing Pavement Preservation 2018, PW3622, Bid Number 029-18; and
2. Direct a Notice Inviting Sealed Bids to be opened on March 15, 2018.

BACKGROUND: This project will seal approximately five (5) miles of streets Citywide with Type II Rubber Polymer Modified Slurry to maintain the conditions of the various streets within the project locations (see Exhibit A) and preserve the street surface life expectancy. The streets on this project were selected based on existing pavement condition with the purpose of sealing the asphalt, filling minor cracks, and restoring skid resistance and aesthetic appeal. Application of a slurry seal provides a thin wearing course surface thereby extending the life of the asphalt.

This work is in addition to the annual major asphalt overlay project currently under design that the City does each year with TransNet and Road Maintenance and Rehabilitation Account Funds.

ENVIRONMENTAL IMPACT: The proposed Street Resurfacing Pavement Preservation 2018 project is categorically exempt from the provisions of the California Environmental Quality Act (CEQA) according to Section 15301 (Class 1) (c) of the CEQA Guidelines. Section 15301 provides an exemption for the maintenance of public facilities.

FISCAL IMPACT: The project funding allocation is included in the proposed Fiscal Year 2017-2018 budget. The Engineer's estimate for this work is \$290,000 with all funding coming from TransNet funds.

PREPARED BY:

REVIEWED BY:

APPROVED BY:

Yazmin Arellano
CITY ENGINEER/
DEPUTY DIRECTOR
OF PUBLIC WORKS

Dirk Epperson
DIRECTOR OF
PUBLIC WORKS



Douglas Williford
CITY MANAGER

Attachment: Exhibit A -Map of Street Resurfacing/Pavement Preservation 2018 Project

Exhibit A - Map of Street Resurfacing Pavement Preservation 2018 Project

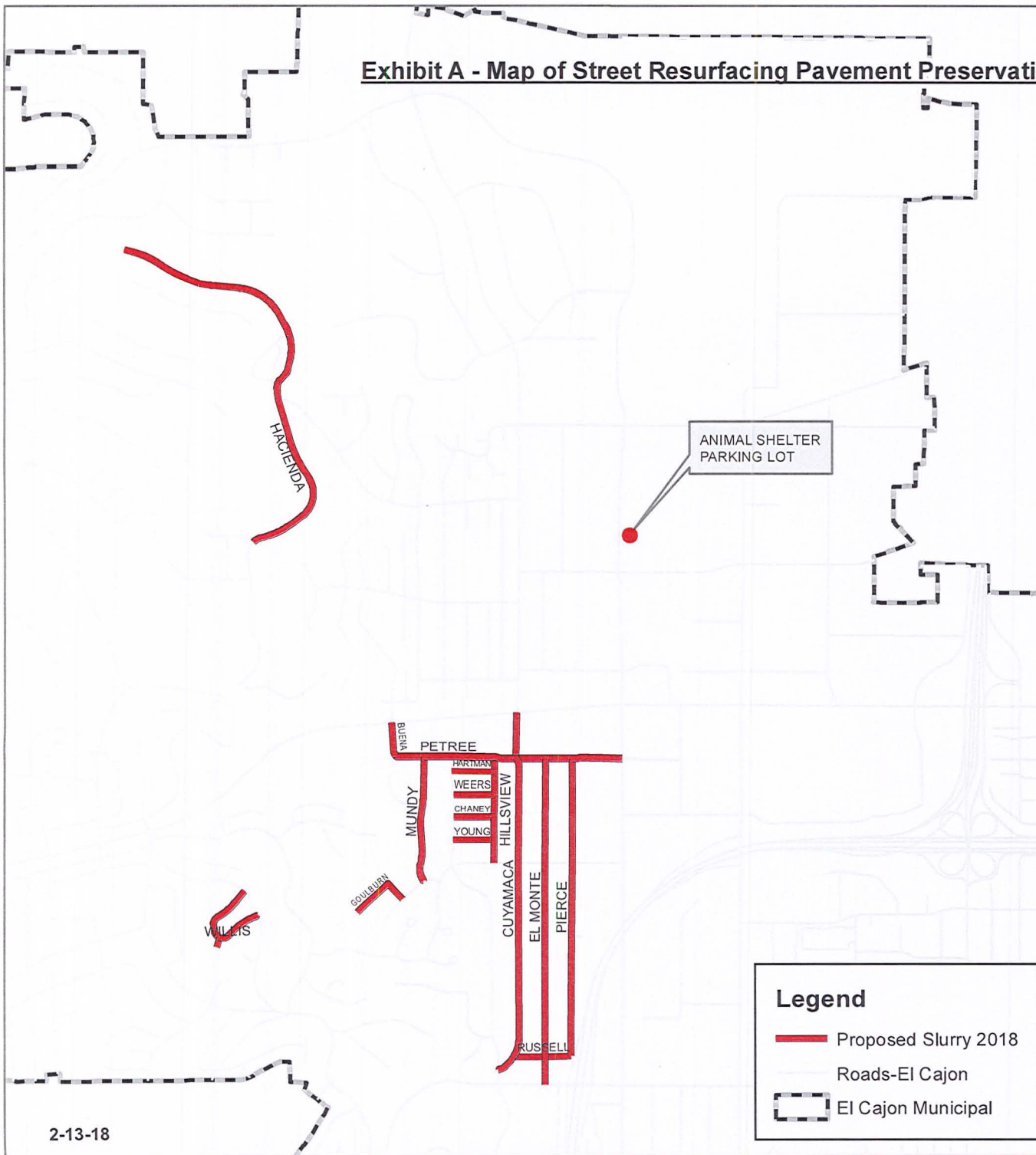

City of El Cajon
Public Works Department



LIST OF STREETS		
No	STREET NAMES	LIMITS
1	BUENA TERRACE	PETREE ST TO FLETCHER PKWY
2	CHANEY ST	DEWANE DR TO HILLSVIEW DR
3	CUYAMACA	DEWANE DR TO FLETCHER DR
4	EL MONTE RD	W MAIN ST TO PETREE ST
5	GOULBURN CT	WAGNER DR TO CUL DE SAC
6	HACIENDA DR	WINDMILL VIEW TO CUL DE SAC
7	HARTMAN DR	DEWANE DR TO HILLSVIEW DR
8	HILLSVIEW DR	WAGNER DR TO PETREE ST
9	MUNDY TERRACE	WAGNER DR TO PETREE ST
10	PETREE ST	BUENA TERRACE TO MARSHALL AVE
11	PIERCE ST	RUSSELL RD PETREE ST
12	RUSSELL RD	CUYAMACA TO PIERCE ST
13	WEERS ST	DEWANE DR TO HILLSVIEW DR
14	WILLIS CT	WILLIS RD TO CUL DE SAC
15	WILLIS RD	ALDWYCH RD TO ALDWYCH RD
16	YOUNG ST	DEWANE DR TO HILLSVIEW DR
17	ANIMAL SHELTER PARKING LOT	

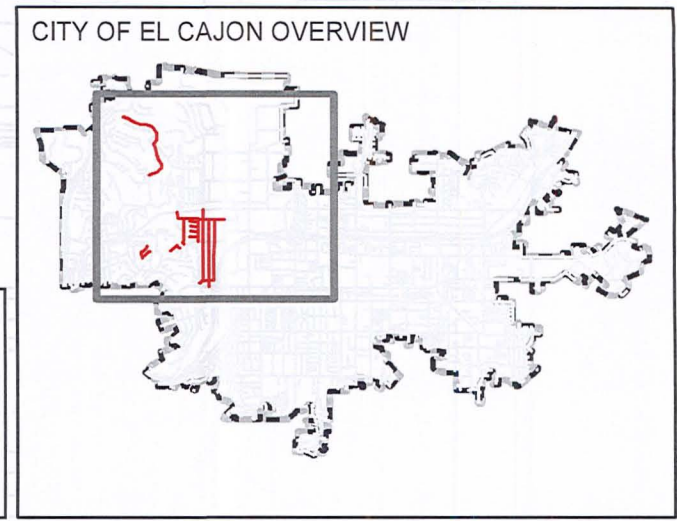

Legend

- Proposed Slurry 2018
- Roads-El Cajon
- ⬜ El Cajon Municipal

RESOLUTION NO. ___-18

RESOLUTION APPROVING
PLANS AND SPECIFICATIONS FOR
STREET RESURFACING/PAVEMENT PRESERVATION 2018
(Bid No. 029-18, PW3622)

WHEREAS, the Deputy Director of Public Works/City Engineer has submitted plans and specifications for the Street Resurfacing/Pavement Preservation 2018 project (the "Project") to seal approximately five (5) miles of streets citywide with Type II Rubber Polymer Modified Slurry to maintain the conditions of the various streets within the Project locations and preserve the street surface life expectancy; and

WHEREAS, it appears to be in the best interests of the City of El Cajon that the plans and specifications for said Project should be approved.

NOW, THEREFORE, BE IT RESOLVED BY THE CITY COUNCIL OF THE CITY OF EL CAJON AS FOLLOWS:

1. That the plans and specifications submitted for the Project by the Deputy Director of Public Works/City Engineer are hereby approved and adopted as the official plans and specifications for said Project.

2. Said plans and specifications are directed to be filed in the office of the Deputy Director of Public Works/City Engineer of the City of El Cajon.

02/13/18 (Item 1.4)

Bid 025-18 – Street Resurfacing-Pavement Preservation 2018 apr 020518

RESOLUTION NO. ___-18

RESOLUTION ORDERING THE WORK AND
DIRECTING PUBLICATION OF NOTICE INVITING BIDS FOR
STREET RESURFACING/PAVEMENT PRESERVATION 2018
(Bid No. 029-18, PW3622)

WHEREAS, plans and specifications have been submitted for the Street Resurfacing/Pavement Preservation 2018 project (the "Project") to seal approximately five (5) miles of streets citywide with Type II Rubber Polymer Modified Slurry to maintain the conditions of the various streets within the project locations and preserve the street surface life expectancy; and

WHEREAS, it appears to be in the best interests of the City that said work should be performed.

NOW, THEREFORE, BE IT RESOLVED BY THE CITY COUNCIL OF THE CITY OF EL CAJON AS FOLLOWS:

1. That the City Council does hereby order that the Project shall be performed.
2. That March 15, 2018, at 2:00 P.M., in the office designated by the Purchasing Agent of the City of El Cajon, 200 Civic Center Way, El Cajon, California, is hereby fixed as the time and place for the opening of bids for said Project.
3. The Purchasing Agent of the City of El Cajon is hereby directed to cause a Notice to Bidders to be published in the newspaper, in accordance with the provisions of law.

02/13/18 (Item 1.4)

Bid 025-18 – Street Resurfacing-Pavement Preservation 2018 ntc 020518

City Clerk Date Stamp

RECEIVED OFFICE OF
CITY CLERK
EL CAJON CA

2018 FEB - 8 P 12: 39

City of El Cajon Agenda Report

MEETING: Feb. 13, 2018

ITEM NO: 1.5



TO: Mayor Wells, Mayor Pro Tem Kendrick,
Councilmembers Goble, Kalasho and McClellan

FROM: Nahid Razi, Purchasing Agent

SUBJECT: Award of Bid No. 026-18 – BMW Police Motorcycle

RECOMMENDATION: That the City Council adopts the next resolution in order awarding the bid to the sole responsive, responsible bidder, Powersports Unlimited, Inc., dba: BMW Motorcycles of Escondido, in the amount of \$26,767.86.

BACKGROUND: On June 27, 2017, the City Council approved the purchase of a replacement police motorcycle as part of the Fiscal Year 2017-2018 budget. Five prospective bidders obtained bid packages, and one response was received and opened at 2:00 p.m. on January 23, 2018. Of the five prospective bidders, two were BMW dealers. The Purchasing Division contacted the other BMW dealer that did not respond to the bid for an explanation. The dealer advised that they misunderstood the documentation requirements and therefore did not submit a complete bid package.

The City currently has five motorcycles in use by the El Cajon Police Department fleet. For over 12 years, the El Cajon Police Department has standardized the BMW R1200 RT-P motorcycle for its motorcycle fleet, which is the same make and model in use by other local law enforcement agencies in San Diego County. The BMW R1200 RT-P is equipped with features that make it one of the safest motorcycles in production. It is lighter, provides greater visibility, and is more maneuverable than other police motorcycles without any loss of engine performance. The motorcycle has an integral anti-lock braking system (ABS) that provides 20% better braking performance as compared to other motorcycles with ABS.

The bid specifications requested bidders to provide trade-in pricing for two 2006 BMW R1200 RT-P motorcycles (VINs: WB10388056ZM19358 and WB10388086ZM19354). These two motorcycles are currently nonoperational, require significant repairs, and are scheduled for retirement. The specifications also included police accessories such as a wireless communication kit and a ticket book holder.

The Purchasing Division, in concurrence with the Chief of Police, recommends award of the bid to the sole responsive, responsible bidder, Powersports Unlimited, Inc., dba BMW Motorcycles of Escondido. The complete proposal is on file in the Purchasing Division.

FISCAL IMPACT: The fiscal impact of this purchase is \$26,767.86. Sufficient funds are available in the Police Miscellaneous Grant Fund (225900) via the California Office of Traffic Safety (OTS) Grant.

PREPARED BY:

REVIEWED BY:

APPROVED BY:

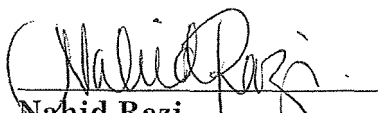
Nahid Razi
PURCHASING AGENT

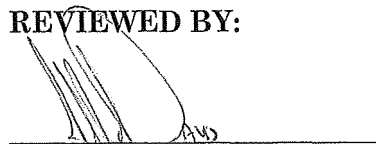
Jeff Davis
CHIEF OF POLICE

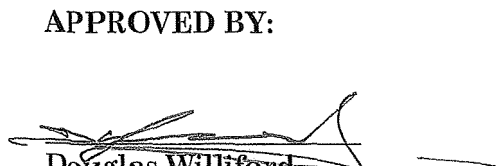
Douglas Williford
CITY MANAGER

RESOLUTION NO. ___-18

RESOLUTION AWARDING BID FOR
BMW POLICE MOTORCYCLE
(Bid No. 026-18)

WHEREAS, on June 27, 2017, the City Council approved the purchase of a replacement BMW R1200 RT-P motorcycle as part of the Fiscal Year 2017-2018 budget; and

WHEREAS, five (5) prospective bidders obtained bid packages and one (1) response was received and publicly opened at 2:00 p.m. on January 23, 2018; and

WHEREAS, the City of El Cajon currently has seven (7) motorcycles in the El Cajon Police Department fleet, and for over 12 years, has standardized the use of BMW R1200 RT-P motorcycle for its fleet; and

WHEREAS, the bid specifications requested bidders to provide trade-in pricing for two 2006 BMW R1200 RT-P motorcycles which are currently nonoperational, require significant repairs, and are scheduled to be retired, as well as optional add-ons such as a wireless communication kit and a ticket book holder; and

WHEREAS, the Purchasing Division, in concurrence with the Chief of Police, recommends award of the bid to the sole responsive, responsible bidder, Powersports Unlimited, Inc., dba BMW Motorcycles of Escondido; and

WHEREAS, the City Council believes it to be in the best interests of the City to award the bid to the sole responsive, responsible bidder as recommended by the Purchasing Division.

NOW, THEREFORE, BE IT RESOLVED BY THE CITY COUNCIL OF THE CITY OF EL CAJON AS FOLLOWS:

1. The City Council hereby finds the foregoing recitals to be true and correct, and are the findings of the City Council.

2. The City Council hereby rejects all bids and proposals except that herein mentioned, and awards the bid for BMW Police Motorcycle to:

Powersports Unlimited, Inc., dba BMW Motorcycles of Escondido

in the amount of \$26,767.86, after the receipt of the two (2) trade-in motorcycles.

3. The Purchasing Agent is authorized and directed to execute the purchase order for said motorcycle on behalf of the City of El Cajon, and to execute such transfer of title documents in favor of Powersports Unlimited, Inc., for the two (2) trade-in motorcycles.

02/13/18 (Item 1.5)

Bid 026-18 – BMW Police Motorcycle (Powersports Unltd dba BMW) 020718

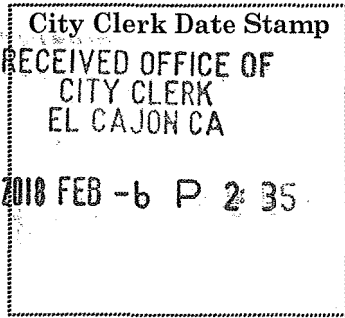

City of El Cajon Agenda Report

MEETING: 02/13/18

ITEM NO: 1.6

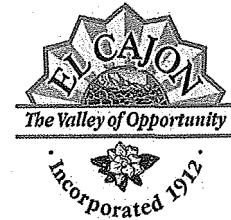

TO: Mayor Wells, Mayor Pro Tem Kendrick,
Councilmembers Goble, Kalasho and McClellan

FROM: Anthony Shute, Director of Community Development

SUBJECT: 1ST AMENDMENT TO FY 2017-18 ONE YEAR ACTION PLAN FOR
RE-ALLOCATION OF AVAILABLE CDBG FUNDS

RECOMMENDATION: That the City Council

- 1) Re-allocates \$76,000 in available unallocated Community Development Block Grant (CDBG) funds to Project PK3582/C0923 Stoney’s Neighborhood Park Improvements, and
- 2) Appropriates \$76,000 of CDBG funding to Parks Capital Improvement Project PK3582 Stoney’s Neighborhood Park Improvements

BACKGROUND

The U.S. Department of Housing and Urban Development (HUD) provides funding annually to eligible jurisdictions relative to CDBG programs through the One Year Action Plan process.

On April 26, 2016, the One Year Action Plan was adopted by the City Council for the FY 2016-17 program year, which included funds for the “Neighborhood Park Improvements” project in the amount of \$350,000. The park is located next to the Ronald Reagan Community Center and the County Library. Design and pre-construction work were initiated during that year and the park was renamed to Stoney’s Neighborhood Park. As design work and cost estimating progressed, staff determined that additional funds would be required to meet escalating construction and material costs.

On April 25, 2017, the One Year Action Plan was adopted by City Council for the FY 2017-18 program year. This Action Plan included an allocation of additional CDBG funds for the Stoney’s Neighborhood Park Improvements project in the amount of \$135,000 for landscape design and improvements that incorporates planting areas adjacent to Ronald Reagan Community Center. Total CDBG allocation amount for this project is currently \$485,000.

Additional CDBG funds are being requested for allocation to this project and will be used for enhanced park security features such as fencing and lighting (estimated at \$32,514), and a 10% construction contingency of the project’s base bid (\$434,867).

Available unallocated CDBG funds have been identified to fund this activity as follows:

Table 1. First Amendment to One-Year Action Plan			
CDBG Project #	Project	Funds Available	Proposed Re-allocations
--	CDBG Unallocated Funds	\$196,000	--
C0923	Stoney's Neighborhood Park Improvements (PK3582)		\$76,200
	TOTAL:	\$196,000	\$76,200

In accordance with the adopted Citizen Participation Plan for this grant funding source, a public hearing for this proposed amendment of the One Year Action Plan is not required since the total change in funding for the Stoney's Park Improvements project does not exceed 25% of the original allocation amount (\$350,000).

FISCAL IMPACT

There is no impact to the General Fund. This action increases the total CDBG appropriation for the Stoney's Neighborhood Park Improvements project PK3582 in the current fiscal year to \$561,000.

PREPARED BY:

REVIEWED BY:

APPROVED BY:

Jamie van Ravesteyn
SR. MANAGEMENT
ANALYST

Anthony Shute
DIRECTOR OF
COMMUNITY
DEVELOPMENT

Douglas Williford
CITY MANAGER

City Clerk Date
Stamp

RECEIVED OFFICE OF
CITY CLERK
EL CAJON CA

2018 FEB -7 A 11: 35

City of El Cajon

Agenda Report

MEETING: February 13, 2018

ITEM NO: 1.7

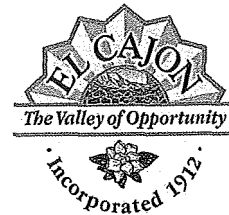

TO: Mayor Wells, Mayor Pro Tem Kendrick,
Councilmembers Goble, Kalasho and McClellan

FROM: Yazmin Arellano, Deputy Director of Public Works/City Engineer

SUBJECT: Approve Contract Change Order for PW3575 ADA Pedestrian Curb Ramp
and Sidewalks 2017 Project, Bid No. 018-18

RECOMMENDATION: That the City Council approves the Contract Change Order for PW3575 ADA Pedestrian Curb Ramp and Sidewalks 2017 Project, Bid No. 018-18, in the amount of \$60,603.50 for Crest Equipment, Inc., for construction and installation of ADA pedestrian curb ramps and related concrete surface improvements. The existing contract amount with Crest Equipment, Inc., is \$213,699.35, and the revised contract amount, if approved, would be \$274,302.85.

BACKGROUND: Project work is currently underway to install new curb ramps, sidewalks, and concrete surface improvements as planned for the Pedestrian Curb Ramp and Sidewalks 2017 Project. Unit bid prices received for the project were very competitive, resulting in lower than expected prices for curb ramps. Due to the lower unit prices, there will be funds remaining in the budget allocated for ADA curb ramps. The City has a future street overlay project which requires approximately 33 ADA compliant pedestrian curb ramps to be installed. Utilizing the unused TransNet and CDBG funds now at a lower cost is a better use of funds. This also allows more of the overlay funds to be spent on repaving and maintaining streets.

This proposed increase to the PW3575 ADA Pedestrian Curb Ramp and Sidewalks 2017 Project, Bid No. 018-18, will exceed twenty-five percent (25%) beyond the original contract amount of \$213,699.35. Council Policy B-4, "Contract Change Orders" requires approval by Council if the proposed contract price change exceeds the twenty-five percent (25%) threshold.

FISCAL IMPACT: The increase in the PW3575 ADA Pedestrian Curb Ramp and Sidewalks 2017 Project, Bid No. 018-18, is \$60,603.50. Sufficient CDBG & TransNet funds are available in current Fiscal Year 2017-18 PW budget activity 550000-9065 PW3575 for this proposed Contract Change Order. The funding used will meet the ADA Upgrade Improvements requirement for CDBG funds and the Maintenance of Effort requirement for TransNet funds.

PREPARED BY:

REVIEWED BY:

APPROVED BY:

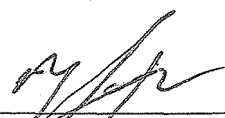
Yazmin Arellano
CITY ENGINEER/
DEPUTY DIRECTOR
OF PUBLIC WORKS

Dirk Epperson
DIRECTOR OF
PUBLIC WORKS

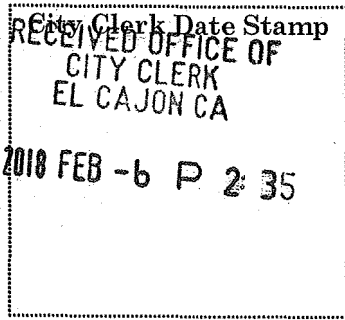

Douglas Williford
CITY MANAGER



MEETING: 2/13/18

City of El Cajon Agenda Report

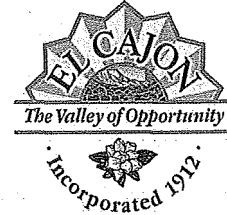
ITEM NO: 1.8



TO: Mayor Wells, Mayor Pro Tem Kendrick,
Councilmembers Goble, Kalasho and McClellan

FROM: Frank Carson, Director of Recreation

SUBJECT: Community Event in the Right-of-Way – RunEC

RECOMMENDATION: That the City Council approve the use of the public right-of-way for the RunEC St. Patrick’s Day Half Marathon / 5K.

BACKGROUND: For the sixth consecutive year, RunEC Foundation is requesting the use of City rights-of-way for a special event in the community. RunEC, a non-profit association, strives to create a world-class running event to support East County community-based organizations. This year’s proceeds are designated for St. Madeleine Sophie’s Center. This racing event features a half marathon, 5K and a “Green Mile” race for children and adults with developmental disabilities. On December 12, 2017, the City Council authorized \$20,000 and City services to support the 2018 event.

The St. Patrick’s Day Half Marathon / 5k is scheduled to take place on Sunday, March 4, 2018, with race participant packet pick-up and set-up planned for Saturday, March 3, 2018. More than 10,000 people are expected for this year’s race and festivities. Race check-in, the sports vendor expo; children’s play area and cross fitness challenge course will be on March 4th, from 8:00 a.m. to 12:00 p.m., on Sulzfeld Way.

The 2017 RunEC event featured a beer garden on public property at the El Cajon Centennial Plaza. This year, the beer garden will be located on private property at the Downtown Café.

The race will begin near the El Cajon archway, travel east on Main Street to Jamacha Road, on to Cuyamaca College Drive, then return along the same route. In accordance with El Cajon Municipal Code Chapter 12.24, staff recommends the City Council approve the use of the public right-of-way for the proposed event because it provides a venue for community participation and creates community awareness for the City, which is in the public interest.

Traffic management has been approved by the City’s Traffic Engineer and will be coordinated with Public Works and Police staff to ensure a safe event. The effective movement of vehicles and pedestrians, to include Marriott construction, in and around the event will be assisted by Police without compromising service to the broader community.

Agenda Report

February 13, 2018

Subject: Community Event in the Right-of-Way – RunEC

Page 2

Approval for phased street closures is requested as follows:

Saturday, March 3, 2018 to Sunday, March 4, 2018

Full Street Closure

12:00 p.m. Saturday to Sulzfeld Way – from Main Street to Rea Avenue
1:00 p.m. Sunday Artist Alley – from Magnolia Avenue to Sulzfeld Way

Sunday, March 4, 2018

Full Street Closures

4:30 a.m. to 10:00 a.m. Main Street – from Van Houten Avenue to Jamacha Road
4:30 a.m. to 10:00 a.m. Magnolia Avenue – from Main Street to Douglas Avenue
4:30 a.m. to 1:00 p.m. Rea Avenue – from Magnolia Avenue to Sulzfeld Way

Partial Street Closures (one or two vehicle travel lanes closed only)

4:30 a.m. to 1:00 p.m. Ballantyne Street – from Park Avenue to Main Street
4:30 a.m. to 1:00 p.m. Park Avenue – from Magnolia Avenue to Ballantyne Street
4:30 a.m. to 1:00 p.m. Jamacha Road – from Main Street to South City Limits

Upon approval, the Special Event Committee will notify the RunEC organization of any additional conditions that need to be met, to include:

- A signed petition from a majority of the affected businesses and residents, to include reference to the hours of requested road closures.
- Any necessary permits, insurance and licenses.

California Environmental Quality Act (CEQA): The proposed project is categorically exempt from the provisions of the California Environmental Quality Act (CEQA) according to Section 15061 (b)(3) the General Rule, which states that California Environmental Quality Act (CEQA) applies only to projects which have the potential for causing a significant effect on the environment. The temporary use of the City's right-of-way for a community event and the detouring of other modes of transportation within City Streets will not have a significant effect on the environment.

FISCAL IMPACT: Funding (\$20,000) for RunEC was approved by City Council on December 12, 2017, and is designated in the Community Services and Events Budget (Activity #103000). Indirect staff costs for the race will be absorbed within the respective department budgets.

PREPARED BY:

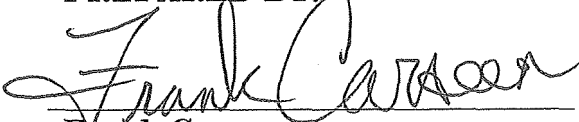
Frank Carson
DIRECTOR OF RECREATION

APPROVED BY:

Douglas Williford
CITY MANAGER

ATTACHMENTS:

1. Sulzfeld Way Site Map
2. Route Maps

The Valley of Opportunity
ST. PATRICK'S DAY
half marathon
5K, Green Mile & EC Craft Beer Invitational  Presented by imortgage®
 Tribes & Clans Competition

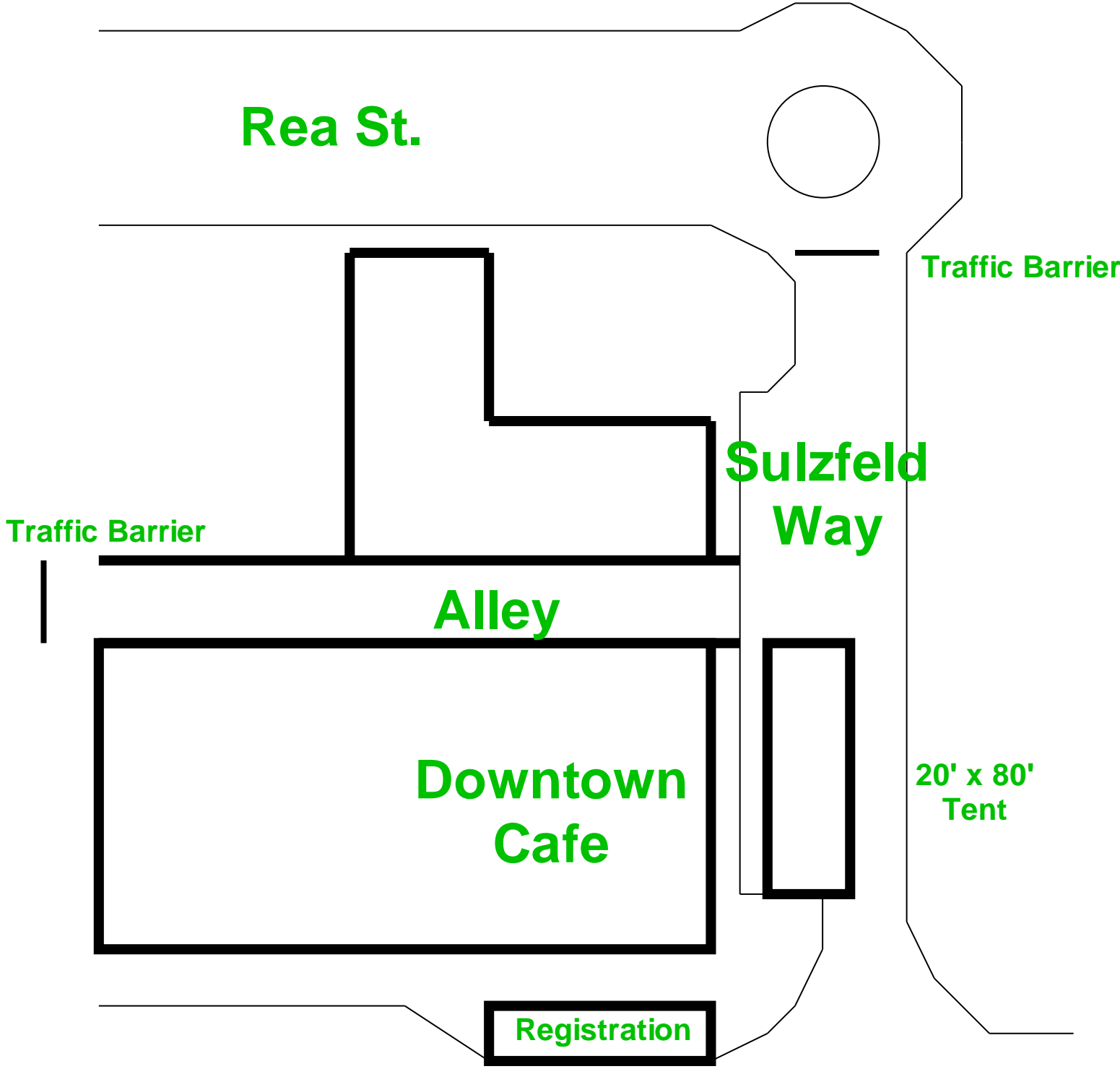

Main St.

Sulzfeld Way is about 46' Wide
Leaving a 26' Fire Lane

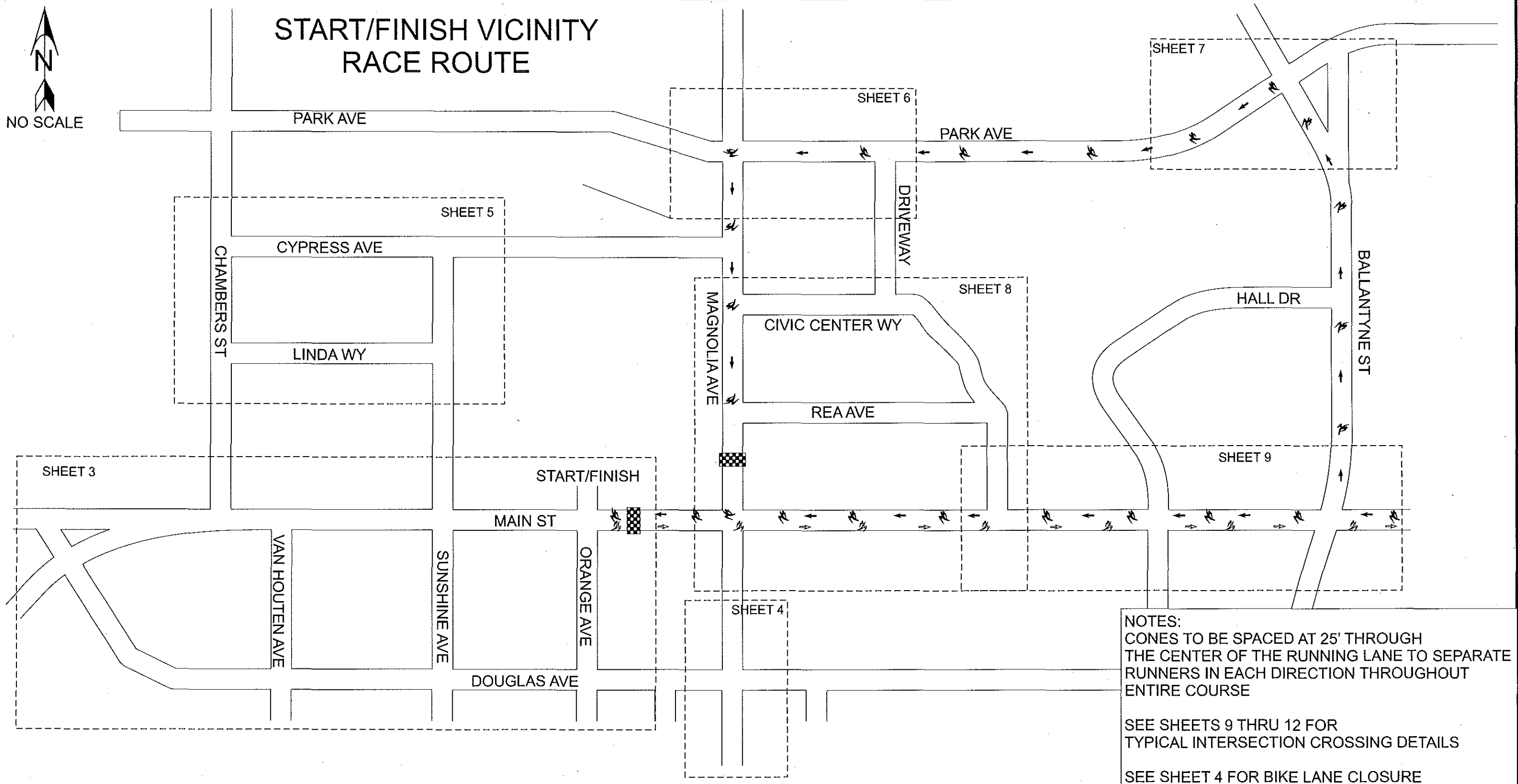

NOTES:
 CONES TO BE SPACED AT 25' THROUGH THE CENTER OF THE RUNNING LANE TO SEPARATE RUNNERS IN EACH DIRECTION THROUGHOUT ENTIRE COURSE

SEE SHEETS 9 THRU 12 FOR TYPICAL INTERSECTION CROSSING DETAILS

SEE SHEET 4 FOR BIKE LANE CLOSURE

TYPICAL CONSTRUCTION SIGNS

SC5(CA)	W20-5 RT	C30(CA)	W20-2	W20-3	W3-4	R4-7a	R3-2	R11-4
SC5(CA)	W4-2 RT	C9A(CA)	W20-2	W20-3	W3-4	R4-7a	R3-1	R11-2

LEGEND: CONE ● SIGN ■ WORK AREA TRAFFIC DIRECTION FLASHING ARROW SIGN (FAS) SIGNALIZED INTERSECTION FLAGGER TYPE II BARRICADE TEMPORARY NO PARKING

THOMAS BROS.: POSTED SPEED LIMIT: TAPER LENGTH: SIGN SPACING: CONE SPACING:

RACE NOTES:
 1. RACE INFORMATION SIGNS SHALL BE PLACED ALONG ROUTE A MINIMUM 2 WEEKS PRIOR TO EVENT.
 2. TEMP. NO PARKING SIGNS SHALL BE PLACED ALONG RACE ROUTE 72 HRS PRIOR TO EVENT

TRAFFIC CONTROL PLAN

CITY OF EL CAJON

DRAWN BY: JAIME BORRUEL Jr.
 HUDSON SAFE-T-LITE
 777 Gable Way
 El Cajon, CA 92020
 PH: 619-441-3644 FAX: 619-441-3652

DATE DRAWN: **FEBRUARY 2016** SCALE: NO SCALE DRAWING NUMBER: SHEET 1 OF 24

TURN AROUND VICINITY RACE ROUTE

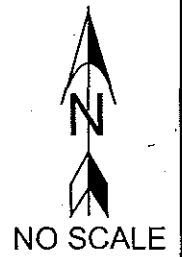
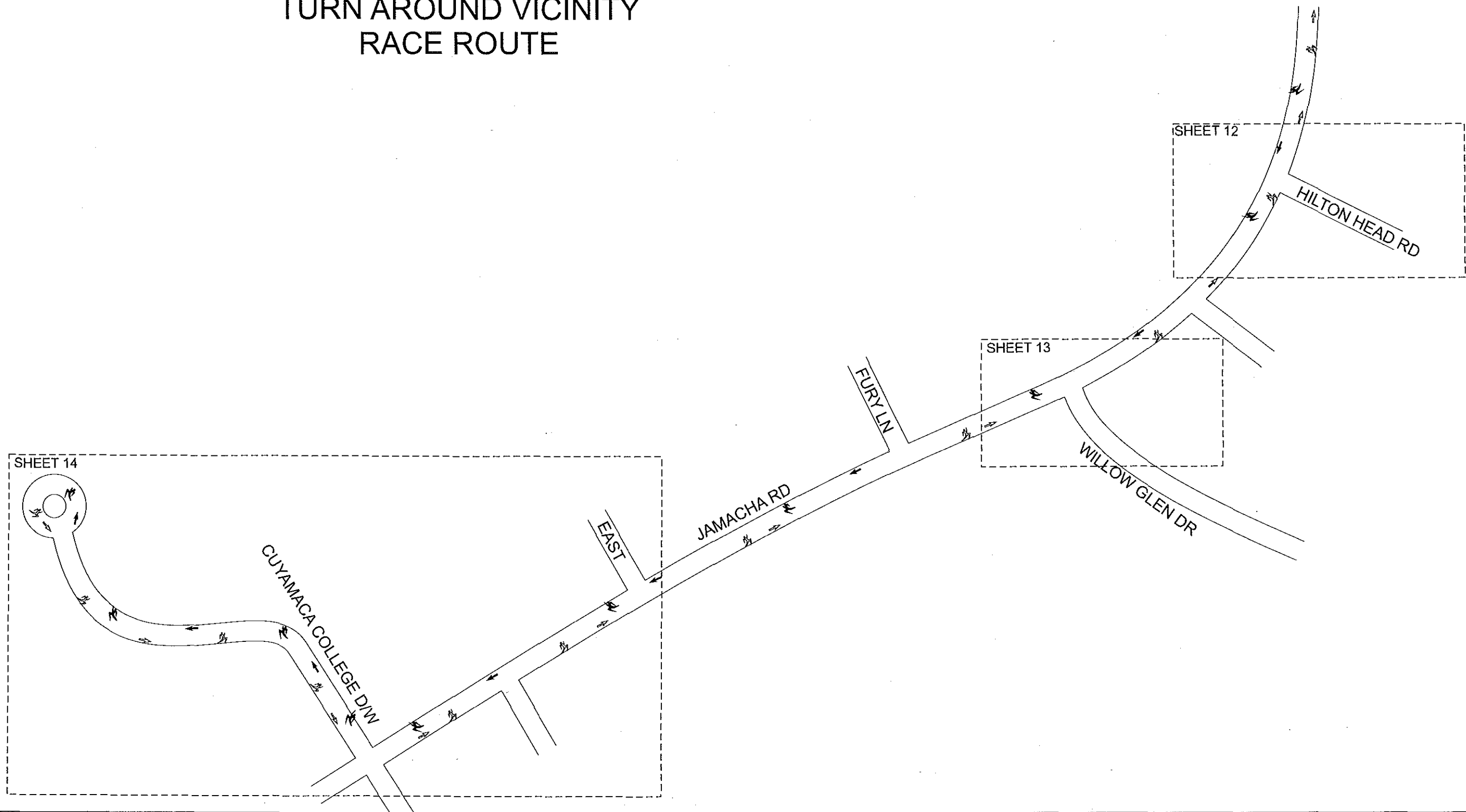

TYPICAL CONSTRUCTION SIGNS

 SC5(CA)	 W20-5 RT	 W4-2 RT	 C30(CA)	 W20-2	 W20-3	 C9A(CA)	 W3-4	 R4-7a	 R3-2	 R11-4	 R3-1	 R11-2
-------------	--------------	-------------	-------------	-----------	-----------	-------------	----------	-----------	----------	-----------	----------	-----------

RACE NOTES:
 1. RACE INFORMATION SIGNS SHALL BE PLACED ALONG ROUTE A MINIMUM 2 WEEKS PRIOR TO EVENT.
 2. TEMP. NO PARKING SIGNS SHALL BE PLACED ALONG RACE ROUTE 72 HRS PRIOR TO EVENT

TRAFFIC CONTROL PLAN

UNINCORPORATED COUNTY AREA

DRAWN BY: JAIME BORRUEL JR.

HUDSON SAFE-T-LITE
777 Gable Way
El Cajon, CA 92020

PH: 619-441-3644 FAX: 619-441-3652

DATE DRAWN: **FEBRUARY 2016** SCALE: NO SCALE DRAWING NUMBER: SHEET 2 OF 24

LEGEND: CONE ● SIGN ■ WORK AREA ▨ TRAFFIC DIRECTION ⇄ FLASHING ARROW SIGN (FAS) ⚡ SIGNALIZED INTERSECTION Ⓢ FLAGGER ■ TYPE II BARRICADE I TEMPORARY NO PARKING TNP ⇄

THOMAS BROS.:	POSTED SPEED LIMIT:	TAPER LENGTH:	SIGN SPACING:	CONE SPACING:	
---------------	---------------------	---------------	---------------	---------------	--

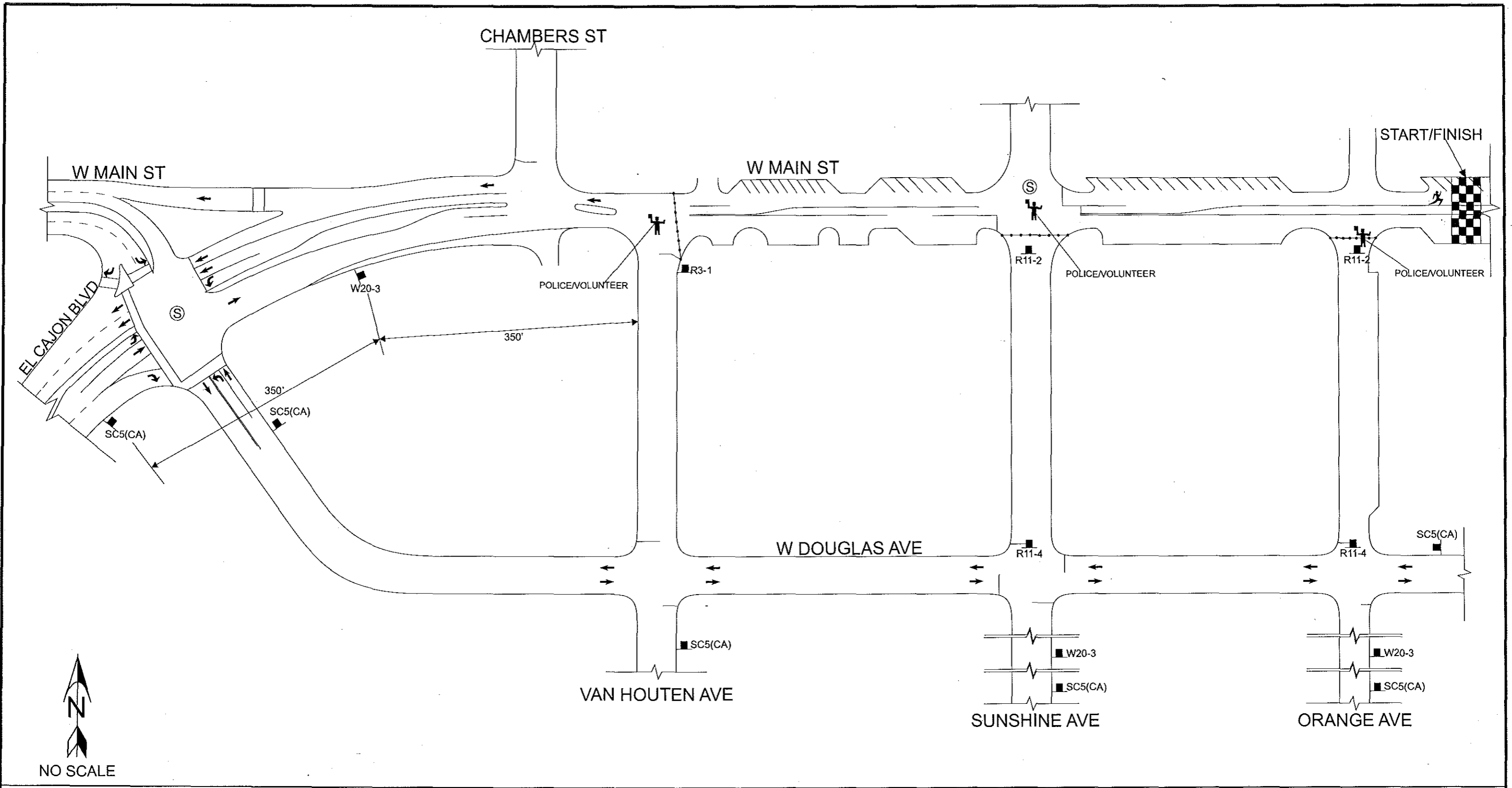

TYPICAL CONSTRUCTION SIGNS

SPECIAL EVENT AHEAD SC5(CA)	RIGHT LANE CLOSED AHEAD W20-5 RT	LANE CLOSED W4-2 RT	LANE CLOSED C30(CA)	DETOUR AHEAD W20-2	ROAD CLOSED AHEAD W20-3	PREPARE TO STOP C9A(CA)	PREPARE TO STOP W3-4	KEEP RIGHT R4-7a	ROAD CLOSED TO THRU TRAFFIC R3-2	ROAD CLOSED R11-4	ROAD CLOSED R3-1	ROAD CLOSED R11-2
--------------------------------	-------------------------------------	------------------------	------------------------	-----------------------	----------------------------	----------------------------	-------------------------	---------------------	-------------------------------------	----------------------	---------------------	----------------------

RACE NOTES:
 1. RACE INFORMATION SIGNS SHALL BE PLACED ALONG ROUTE A MINIMUM 2 WEEKS PRIOR TO EVENT.
 2. TEMP. NO PARKING SIGNS SHALL BE PLACED ALONG RACE ROUTE 72 HRS PRIOR TO EVENT

TRAFFIC CONTROL PLAN

CITY OF EL CAJON

DRAWN BY: JAIME BORRUEL Jr.
 HUDSON SAFE-T-LITE
 777 Gable Way
 El Cajon, CA 92020
 PH: 619-441-3644 FAX: 619-441-3652

CITY

LEGEND: CONE ● SIGN ■ WORK AREA TRAFFIC DIRECTION FLASHING ARROW SIGN (FAS) SIGNALIZED INTERSECTION FLAGGER TYPE II BARRICADE TEMPORARY NO PARKING				
THOMAS BROS.:	POSTED SPEED LIMIT:	TAPER LENGTH:	SIGN SPACING:	CONES SPACING:

DATE DRAWN: **FEBRUARY 2016** SCALE: NO SCALE DRAWING NUMBER: SHEET 3 OF 24

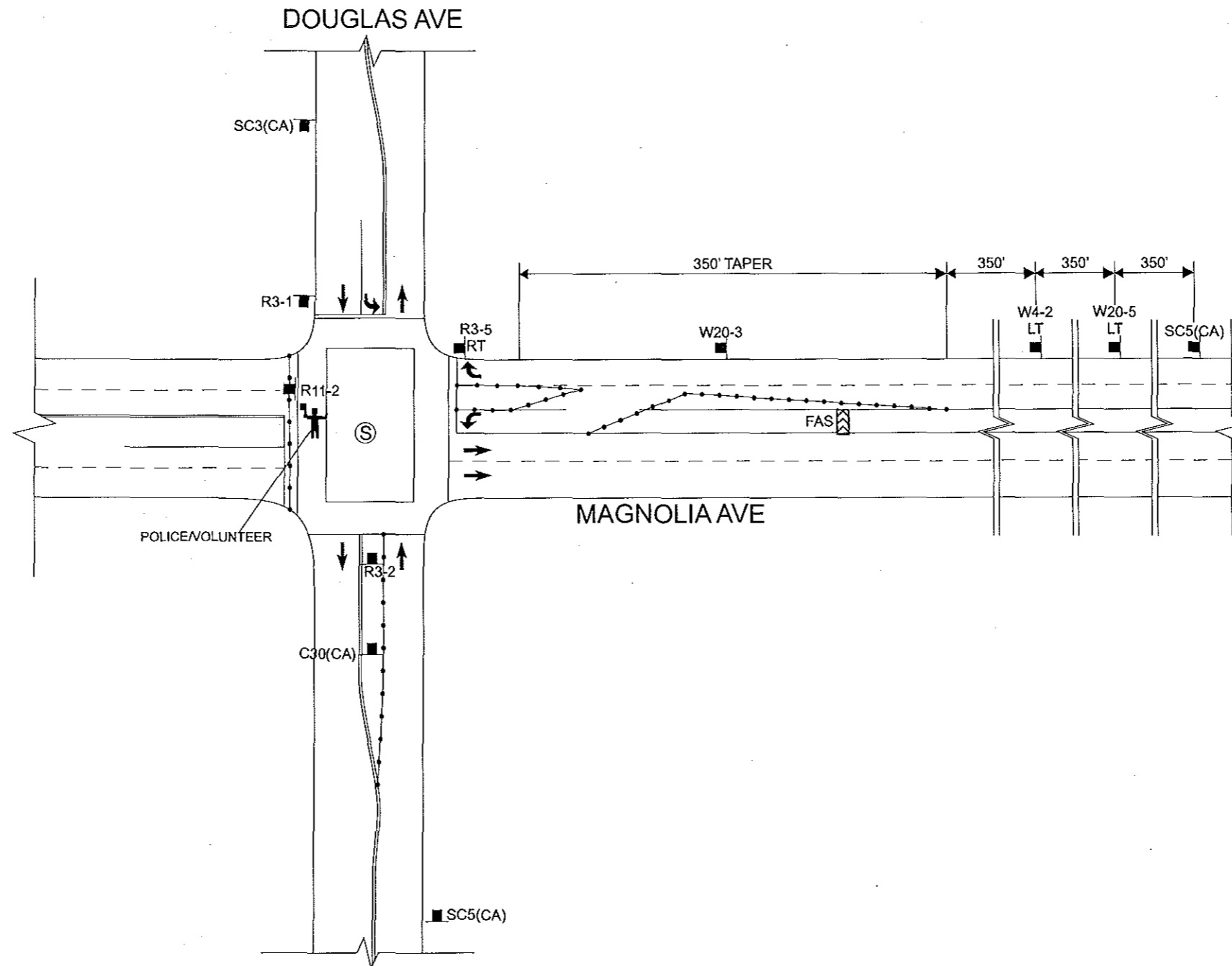

NO SCALE

TYPICAL CONSTRUCTION SIGNS

RACE NOTES:
 1. RACE INFORMATION SIGNS SHALL BE PLACED ALONG ROUTE A MINIMUM 2 WEEKS PRIOR TO EVENT.
 2. TEMP. NO PARKING SIGNS SHALL BE PLACED ALONG RACE ROUTE 72 HRS PRIOR TO EVENT

TRAFFIC CONTROL PLAN

CITY OF EL CAJON

DRAWN BY: JAIME BORRUEL Jr.
 HUDSON SAFE-T-LITE
 777 Gable Way
 El Cajon, CA 92020
 PH: 619-441-3644 FAX: 619-441-3652

DATE DRAWN: FEBRUARY 2016
 SCALE: NO SCALE
 DRAWING NUMBER: SHEET 4 OF 24

LEGEND: CONE ● SIGN ■ WORK AREA [Hatched] TRAFFIC DIRECTION ⇄ FLASHING ARROW SIGN (FAS) [Flashing Arrow] SIGNALIZED INTERSECTION (S) FLAGGER [Flagger] TYPE II BARRICADE [Type II Barricade] TEMPORARY NO PARKING [TNP]

THOMAS BROS.:	POSTED SPEED LIMIT:	TAPER LENGTH:	SIGN SPACING:	CONE SPACING:
---------------	---------------------	---------------	---------------	---------------

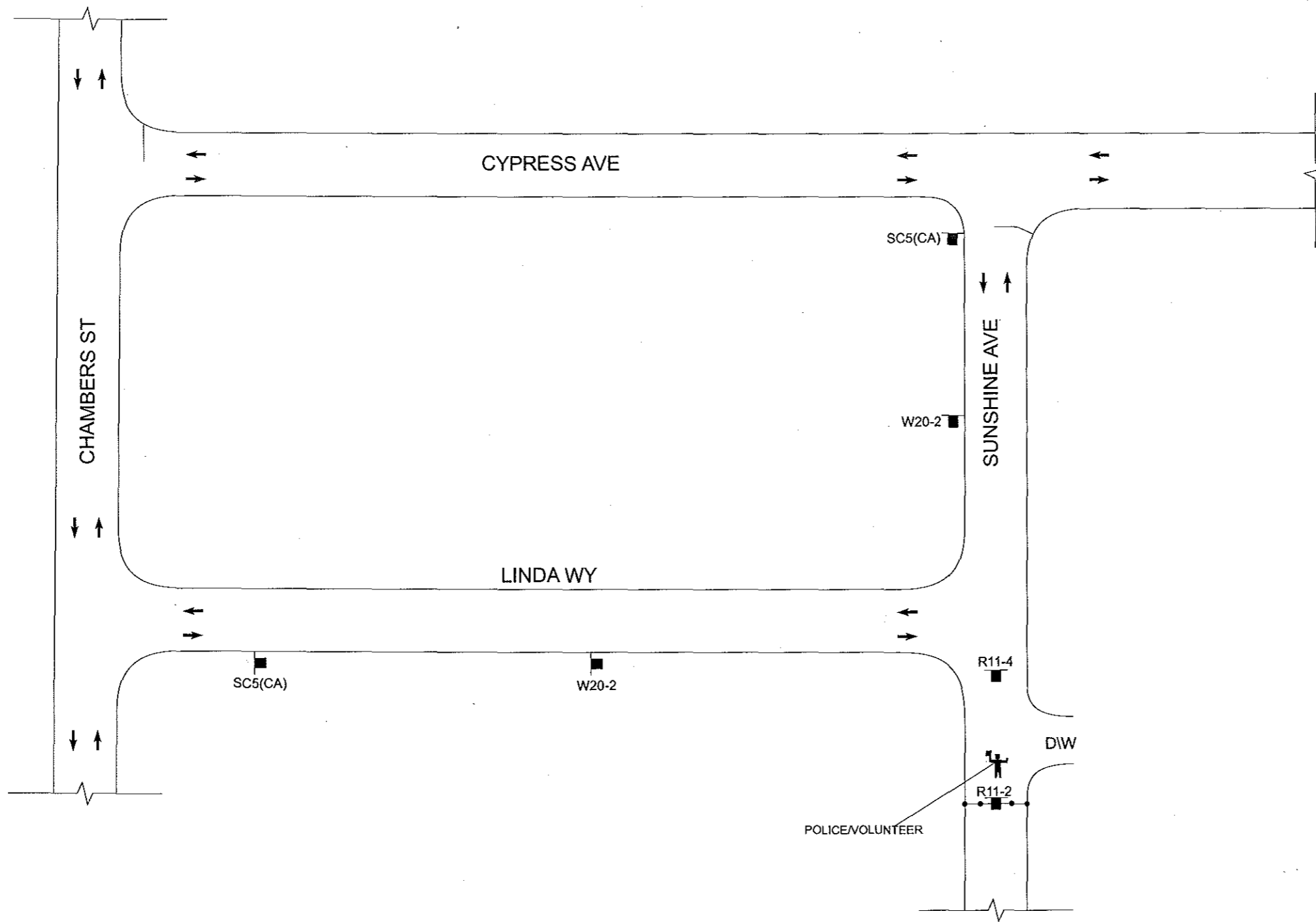

NO SCALE

TYPICAL CONSTRUCTION SIGNS

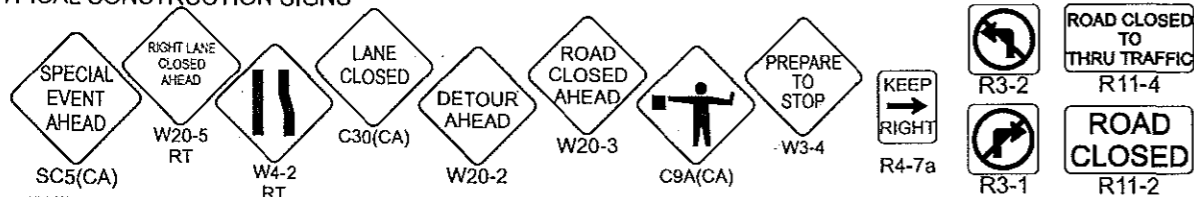

RACE NOTES:

1. RACE INFORMATION SIGNS SHALL BE PLACED ALONG ROUTE A MINIMUM 2 WEEKS PRIOR TO EVENT.
2. TEMP. NO PARKING SIGNS SHALL BE PLACED ALONG RACE ROUTE 72 HRS PRIOR TO EVENT

TRAFFIC CONTROL PLAN

CITY OF EL CAJON

DRAWN BY: JAIME BORRUEL Jr.
 HUDSON SAFE-T-LITE
 777 Gable Way
 El Cajon, CA 92020

CITY

PH: 619-441-3644 FAX: 619-441-3652

DATE DRAWN: FEBRUARY 2016

SCALE: NO SCALE

DRAWING NUMBER: SHEET 5 OF 24

LEGEND: CONE ●	SIGN ■	WORK AREA ▨	TRAFFIC DIRECTION ⇄	FLASHING ARROW SIGN (FAS) ⚡	SIGNALIZED INTERSECTION (S)	FLAGGER ■	TYPE II BARRICADE I	TEMPORARY NO PARKING TNP ⇄
THOMAS BROS.:	POSTED SPEED LIMIT:	TAPER LENGTH:	SIGN SPACING:	CONES SPACING:				

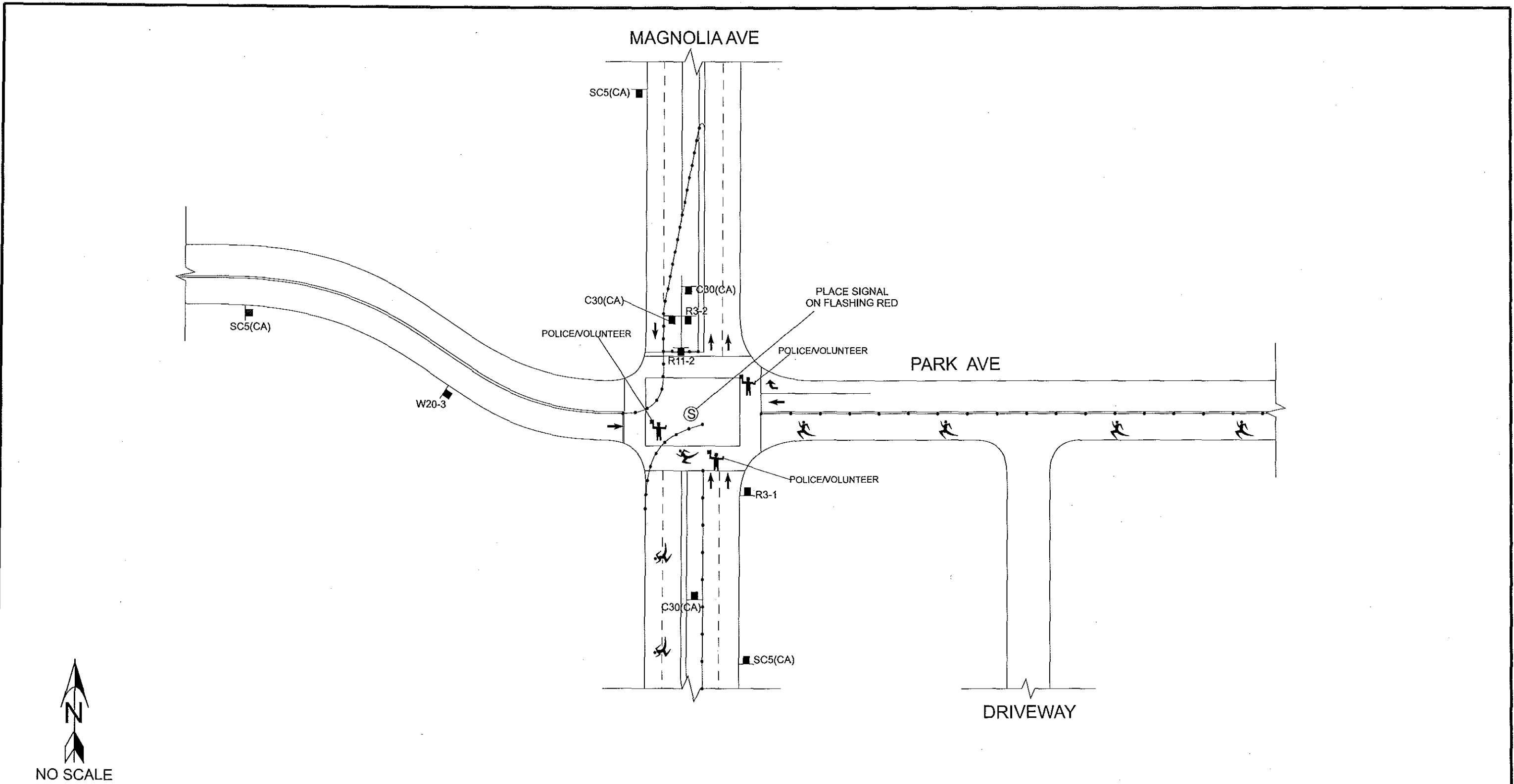

TYPICAL CONSTRUCTION SIGNS

--	--	--	--	--	--	--	--	--	--	--	--	--

RACE NOTES:
 1. RACE INFORMATION SIGNS SHALL BE PLACED ALONG ROUTE A MINIMUM 2 WEEKS PRIOR TO EVENT.
 2. TEMP. NO PARKING SIGNS SHALL BE PLACED ALONG RACE ROUTE 72 HRS PRIOR TO EVENT

LEGEND: CONE ● SIGN ■ WORK AREA TRAFFIC DIRECTION FLASHING ARROW SIGN (FAS) SIGNALIZED INTERSECTION FLAGGER ■ TYPE II BARRICADE I TEMPORARY NO PARKING

THOMAS BROS.: POSTED SPEED LIMIT: TAPER LENGTH: SIGN SPACING: CONE SPACING:

TRAFFIC CONTROL PLAN

CITY OF EL CAJON

DRAWN BY: JAIME BORRUEL JR.		CITY
HUDSON SAFE-T-LITE 777 Gable Way El Cajon, CA 92020		
PH: 619-441-3644 FAX: 619-441-3652	DATE DRAWN:	DRAWING NUMBER:
FEBRUARY 2016	NO SCALE	SHEET 6 OF 24

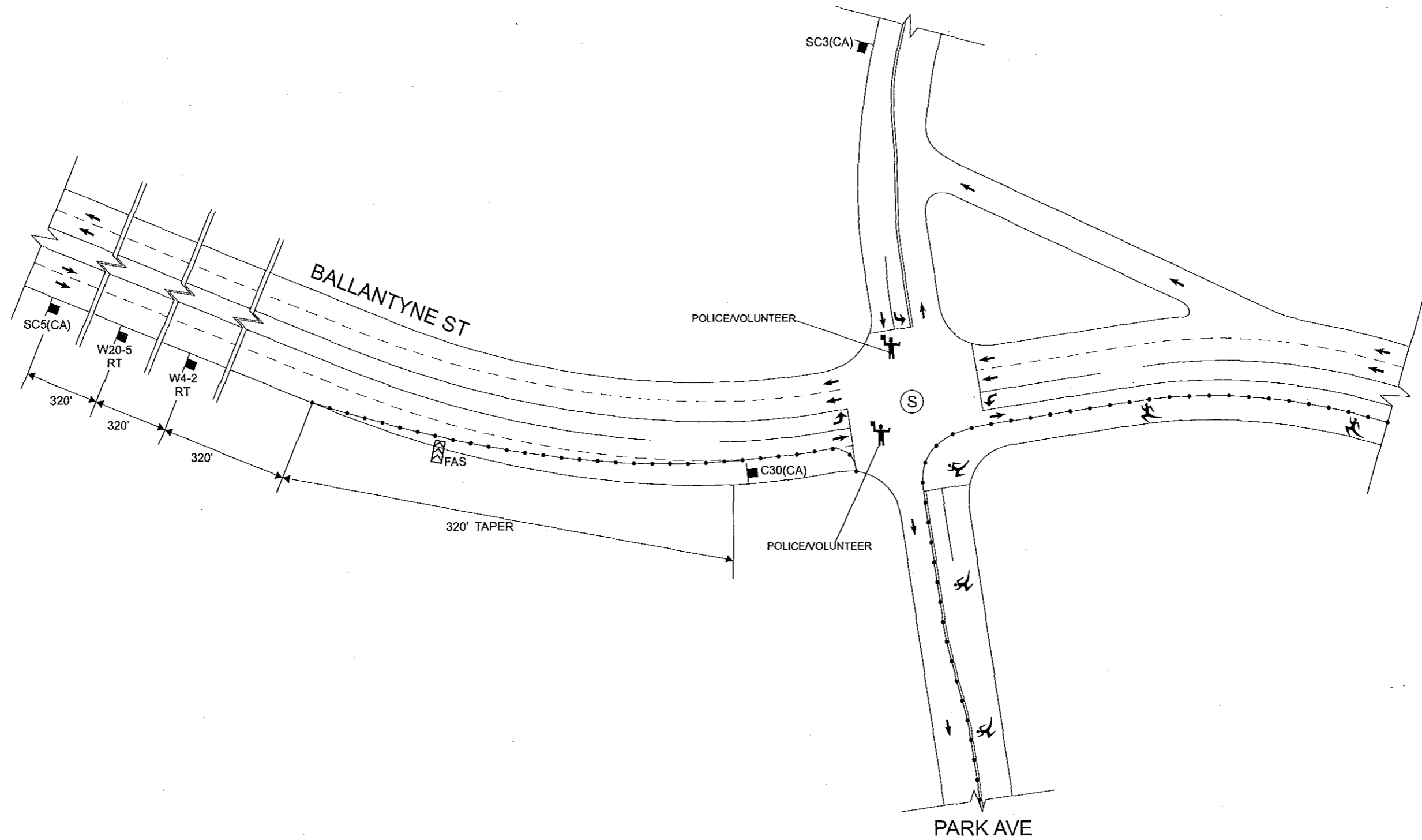

NO SCALE

TYPICAL CONSTRUCTION SIGNS

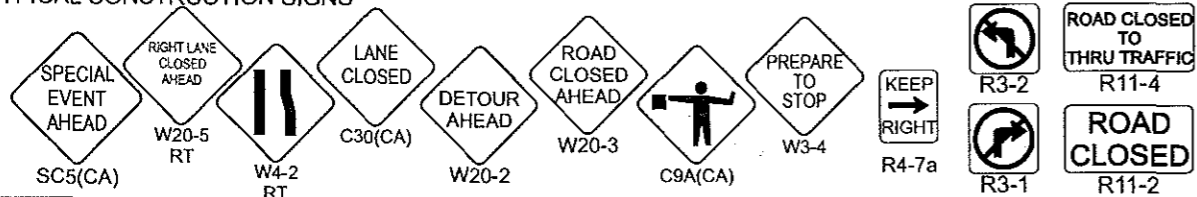

RACE NOTES:

1. RACE INFORMATION SIGNS SHALL BE PLACED ALONG ROUTE A MINIMUM 2 WEEKS PRIOR TO EVENT.
2. TEMP. NO PARKING SIGNS SHALL BE PLACED ALONG RACE ROUTE 72 HRS PRIOR TO EVENT

TRAFFIC CONTROL PLAN

CITY OF EL CAJON

DRAWN BY: JAIME BORRUEL JR.

HUDSON SAFE-T-LITE
777 Gable Way
El Cajon, CA 92020

CITY

PH: 619-441-3644 FAX: 619-441-3652

DATE DRAWN:

SCALE:

DRAWING NUMBER:

FEBRUARY 2016

NO SCALE

SHEET 7 OF 24

LEGEND: CONE ●	SIGN ■	WORK AREA ▨	TRAFFIC DIRECTION ⇄	FLASHING ARROW SIGN (FAS) ⚡	SIGNALIZED INTERSECTION (S)	FLAGGER ■	TYPE II BARRICADE I	TEMPORARY NO PARKING (TNP) ⇄
THOMAS BROS.:	POSTED SPEED LIMIT:	TAPER LENGTH:	SIGN SPACING:	CONES SPACING:				

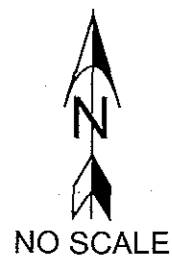
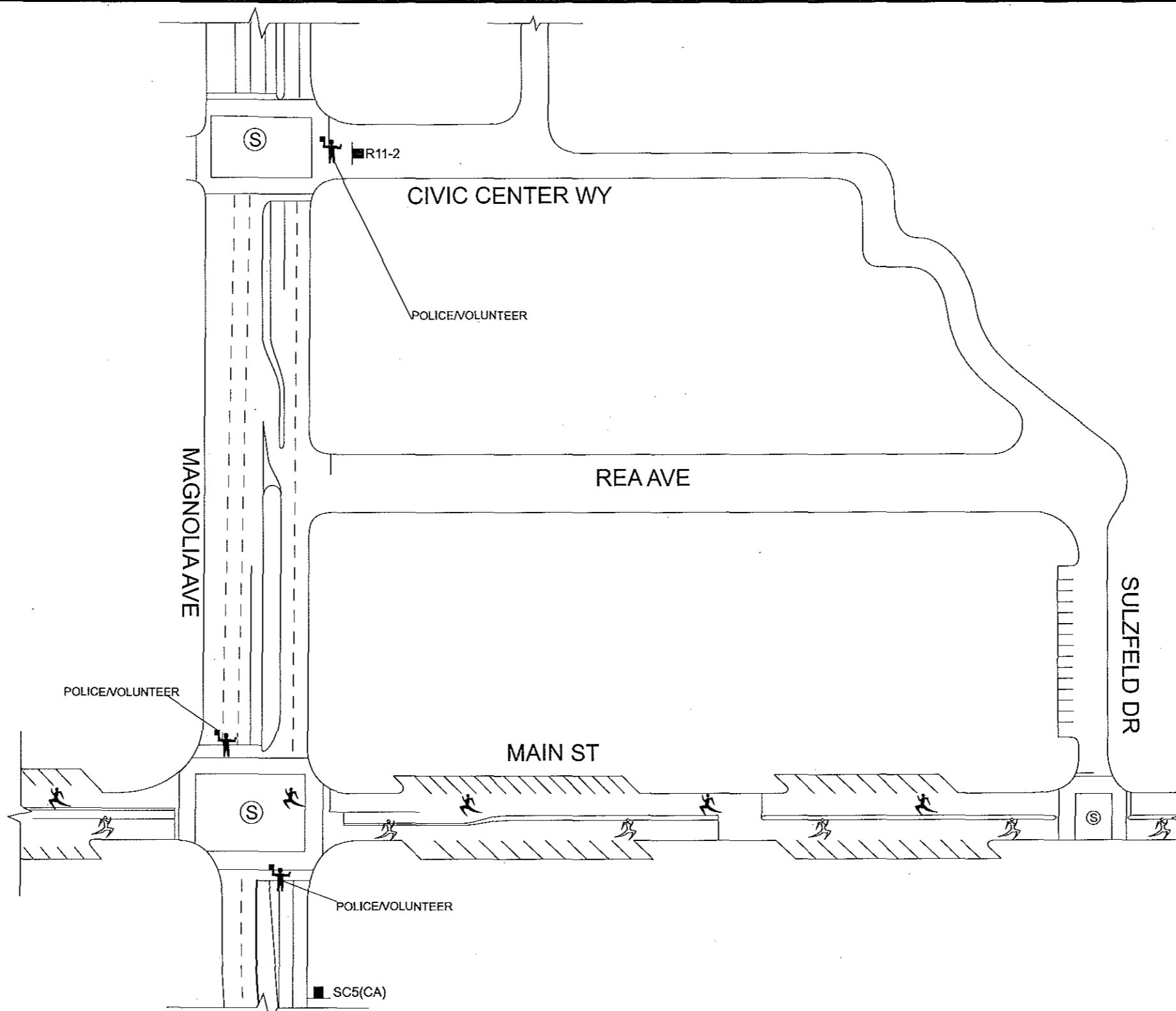

TYPICAL CONSTRUCTION SIGNS

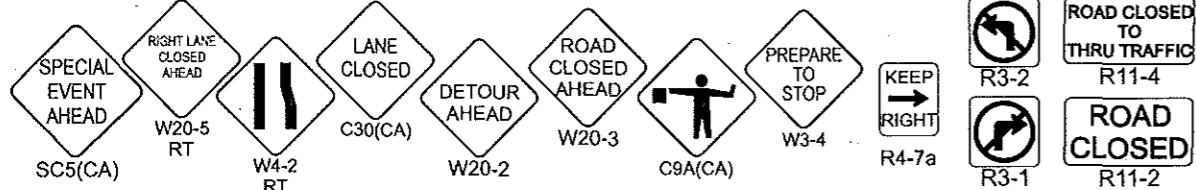

RACE NOTES:

1. RACE INFORMATION SIGNS SHALL BE PLACED ALONG ROUTE A MINIMUM 2 WEEKS PRIOR TO EVENT.
2. TEMP. NO PARKING SIGNS SHALL BE PLACED ALONG RACE ROUTE 72 HRS PRIOR TO EVENT

TRAFFIC CONTROL PLAN

CITY OF EL CAJON

DRAWN BY: JAIME BORRUEL Jr.

HUDSON SAFE-T-LITE
777 Gable Way
El Cajon, CA 92020

PH: 619-441-3644 FAX: 619-441-3652
DATE DRAWN:

SCALE:
NO SCALE

DRAWING NUMBER:
SHEET 8 OF 24

LEGEND: CONE ● SIGN ■ WORK AREA [Hatched Box] TRAFFIC DIRECTION [Arrow] FLASHING ARROW SIGN (FAS) [Flashing Arrow] SIGNALIZED INTERSECTION (S) FLAGGER [Stick Figure] TYPE II BARRICADE [I] TEMPORARY NO PARKING [TNP]

THOMAS BROS.:	POSTED SPEED LIMIT:	TAPER LENGTH:	SIGN SPACING:	CONE SPACING:
---------------	---------------------	---------------	---------------	---------------

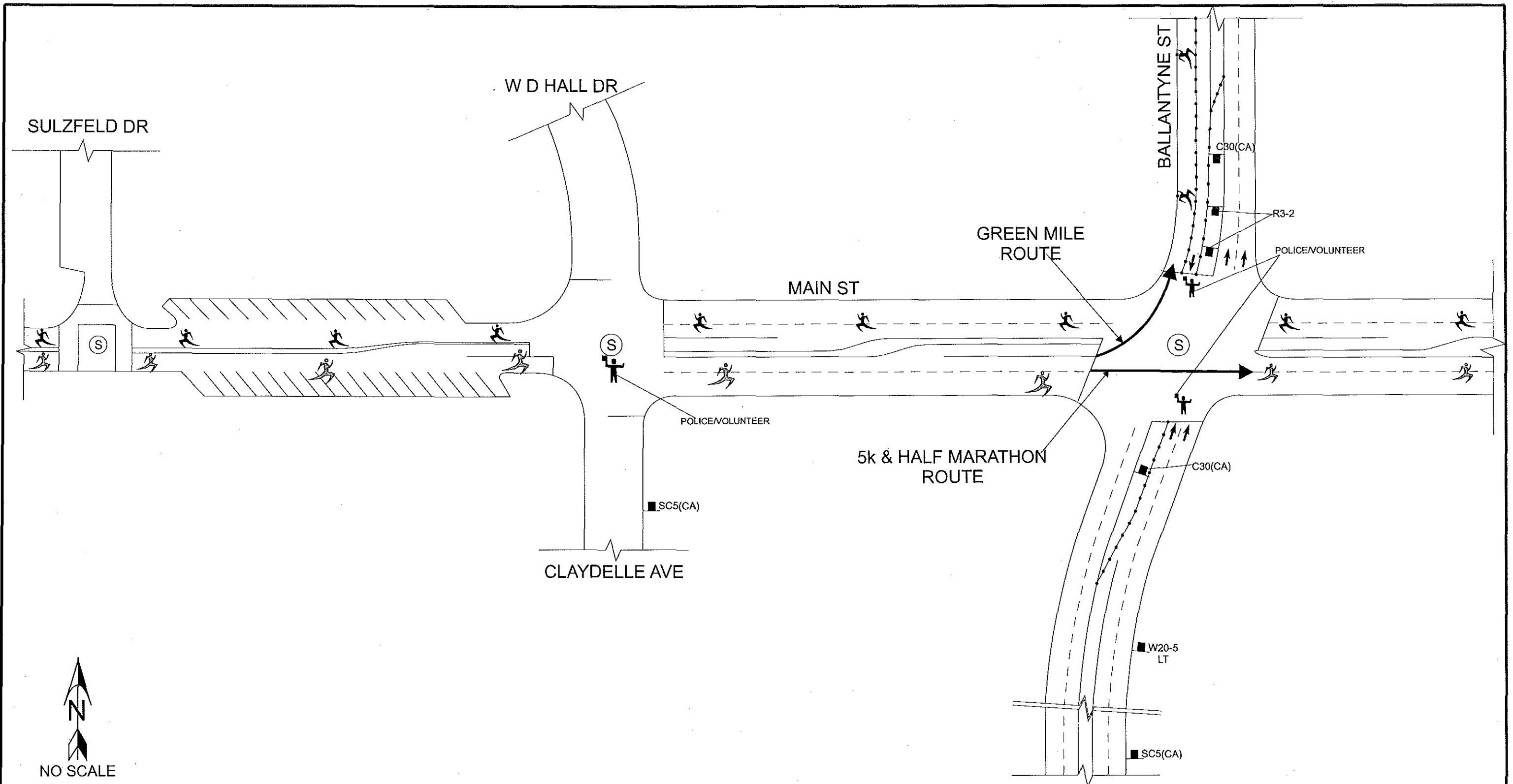

TYPICAL CONSTRUCTION SIGNS

RACE NOTES:
 1. RACE INFORMATION SIGNS SHALL BE PLACED ALONG ROUTE A MINIMUM 2 WEEKS PRIOR TO EVENT.
 2. TEMP. NO PARKING SIGNS SHALL BE PLACED ALONG RACE ROUTE 72 HRS PRIOR TO EVENT

TRAFFIC CONTROL PLAN

CITY OF EL CAJON

DRAWN BY: JAIME BORRUEL Jr.
 HUDSON SAFE-T-LITE
 777 Gable Way
 El Cajon, CA 92020
 PH: 619-441-3644 FAX: 619-441-3652

DATE DRAWN: **FEBRUARY 2016** SCALE: NO SCALE DRAWING NUMBER: SHEET 9 OF 24

LEGEND: CONE ● SIGN ■ WORK AREA TRAFFIC DIRECTION FLASHING ARROW SIGN (FAS) SIGNALIZED INTERSECTION (S) FLAGGER TYPE II BARRICADE TEMPORARY NO PARKING

THOMAS BROS.:	POSTED SPEED LIMIT:	TAPER LENGTH:	SIGN SPACING:	CONE SPACING:
---------------	---------------------	---------------	---------------	---------------

CONTINUE HERE

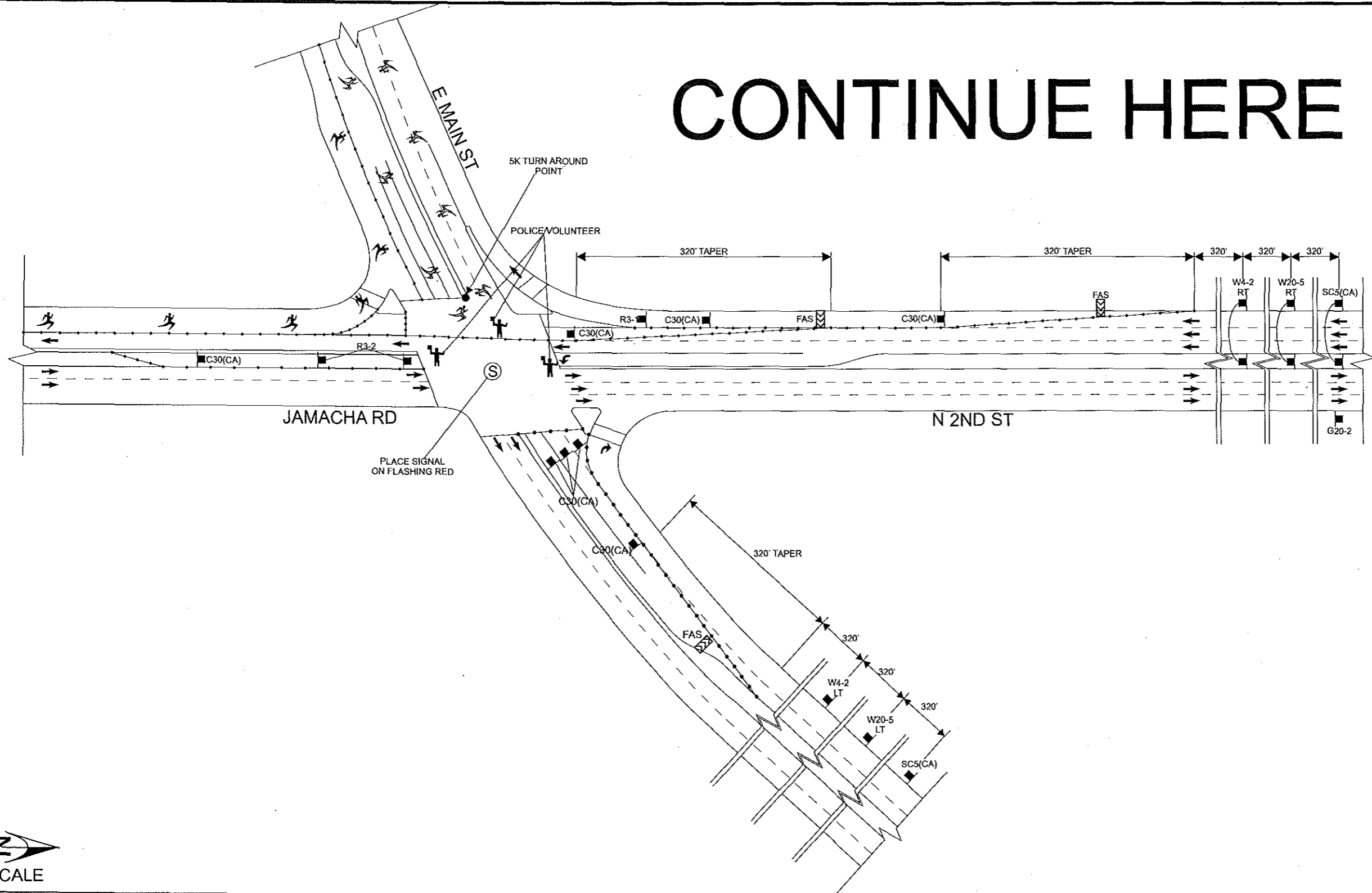

NO SCALE

TYPICAL CONSTRUCTION SIGNS

RACE NOTES:
 1. RACE INFORMATION SIGNS SHALL BE PLACED ALONG ROUTE A MINIMUM 2 WEEKS PRIOR TO EVENT.
 2. TEMP. NO PARKING SIGNS SHALL BE PLACED ALONG RACE ROUTE 72 HRS PRIOR TO EVENT

TRAFFIC CONTROL PLAN

CITY OF EL CAJON

DRAWN BY: JAIME BORRUEL Jr.
 HUDSON SAFE-T-LITE
 777 Gable Way
 El Cajon, CA 92020
 PH: 619-441-3644 FAX: 619-441-3652

DATE DRAWN: FEBRUARY 2016

CITY: _____

SCALE: NO SCALE

DRAWING NUMBER: SHEET 10 OF 24

LEGEND: CONE ● SIGN ■ WORK AREA [diagonal lines] TRAFFIC DIRECTION ⇄ FLASHING ARROW SIGN (FAS) [zigzag arrow] SIGNALIZED INTERSECTION (S) FLAGGER [square with flag] TYPE II BARRICADE [I] TEMPORARY NO PARKING [TNP]

THOMAS BROS.:	POSTED SPEED LIMIT:	TAPER LENGTH:	SIGN SPACING:	CONE SPACING:
---------------	---------------------	---------------	---------------	---------------

BIKE LANE CLOSURE AND ADVANCE NOTIFICATION SIGN JAMACHA ROAD

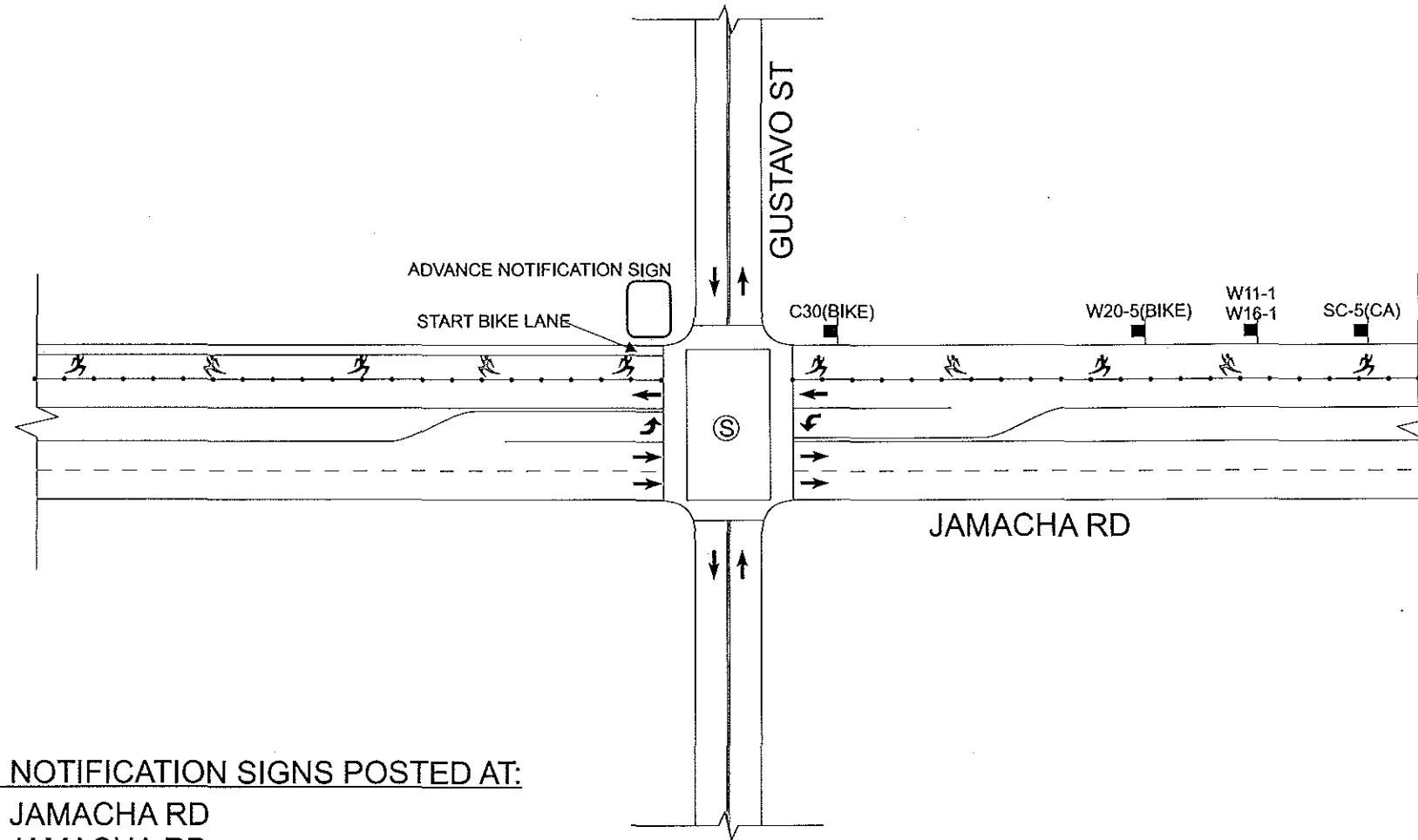

BIKE LANE CLOSURE ADVANCE NOTIFICATION SIGNS POSTED AT:

- E CHASE AVE & JAMACHA RD
- BARBHAM ST & JAMACHA RD
- HILTON HEAD RD & JAMACHA RD
- WILLOW GLEN DR & JAMACHA RD
- FURY LN & JAMACHA RD



TYPICAL CONSTRUCTION SIGNS

SC5(CA)	W20-5 RT	C30(CA)	W20-2	W20-3	W3-4	R4-7a	R3-2	R11-4
	W4-2 RT				C9A(CA)		R3-1	R11-2

RACE NOTES:

1. RACE INFORMATION SIGNS SHALL BE PLACED ALONG ROUTE A MINIMUM 2 WEEKS PRIOR TO EVENT.
2. TEMP. NO PARKING SIGNS SHALL BE PLACED ALONG RACE ROUTE 72 HRS PRIOR TO EVENT

TRAFFIC CONTROL PLAN

UN-INCORPORATED AREA OF EL CAJON

DRAWN BY: JAIME BORRUEL Jr.

HUDSON SAFE-T-LITE
777 Gable Way
El Cajon, CA 92020

PH: 619-441-3644 FAX: 619-441-3652

DATE DRAWN:

FEBRUARY 2016

SCALE:

NO SCALE

DRAWING NUMBER:

SHEET 11 OF 24

LEGEND: CONE ●	SIGN ■	WORK AREA ▨	TRAFFIC DIRECTION ⇄	FLASHING ARROW SIGN (FAS) ⚡	SIGNALIZED INTERSECTION (S)	FLAGGER ■	TYPE II BARRICADE I	TEMPORARY NO PARKING (TNP) ⚡
THOMAS BROS.:	POSTED SPEED LIMIT:	TAPER LENGTH:	SIGN SPACING:	CONE SPACING:				

NOTE:
TYPICAL FOR BRABHAM & ALL OTHER
INTERSECTIONS WITH JAMACHA ROAD
AND COUNTY ROADS.

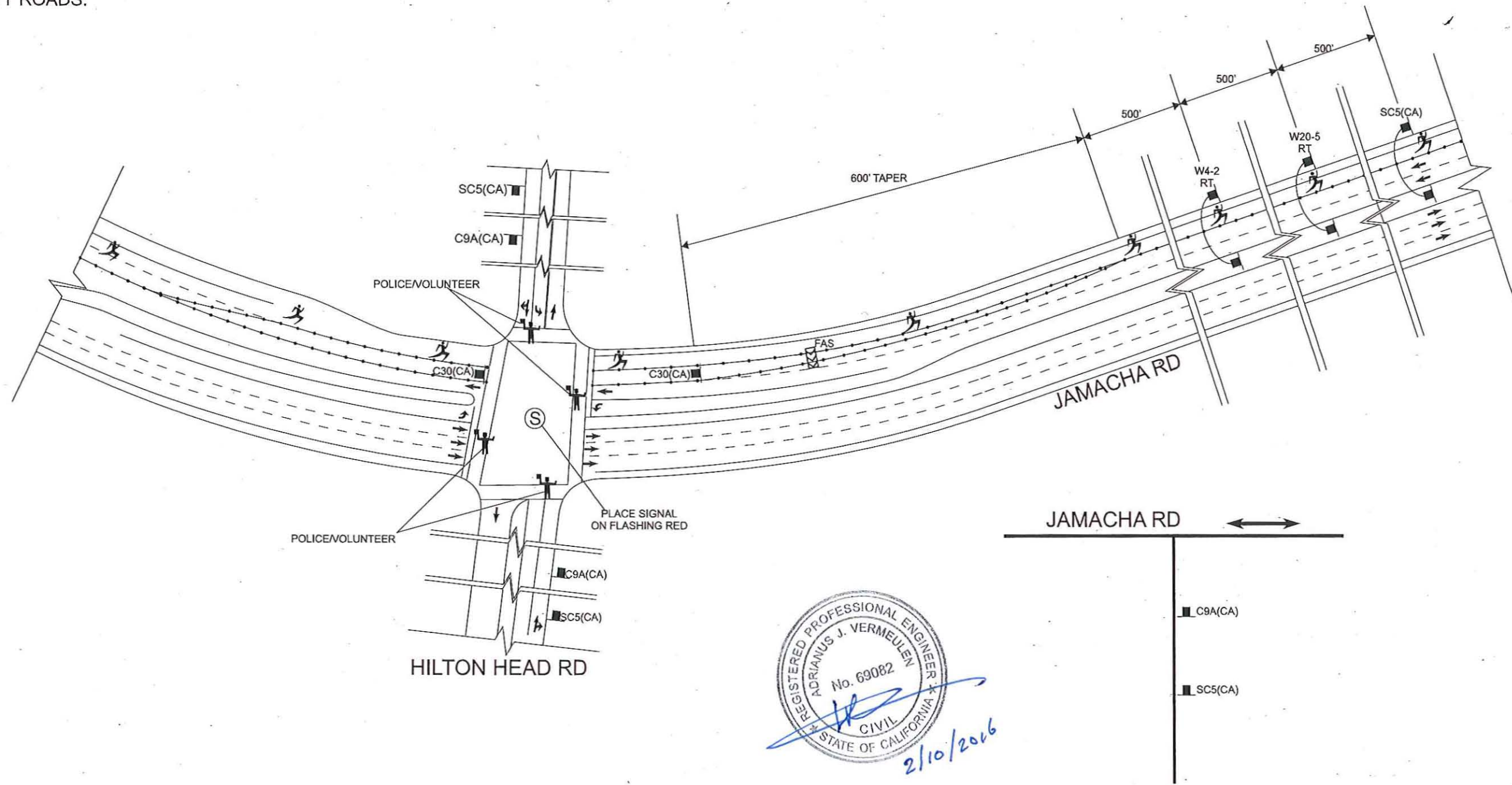

REGISTERED PROFESSIONAL ENGINEER
ADRIANUS J. VERMEULEN
No. 69082
CIVIL
STATE OF CALIFORNIA
2/10/2016

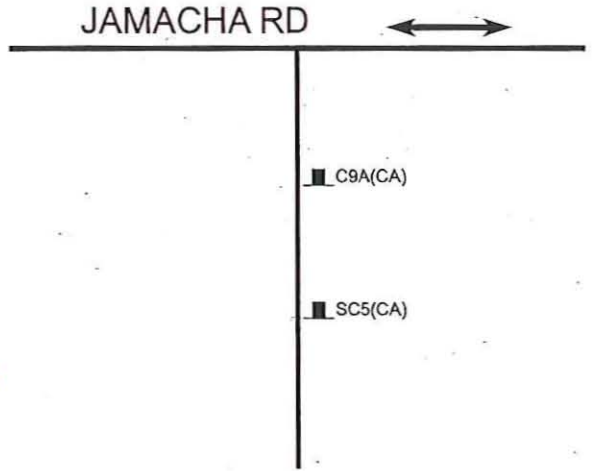

TYPICAL FOR "T" INTERSECTIONS



TYPICAL CONSTRUCTION SIGNS

SC5(CA)	W20-5 RT	C30(CA)	W20-2	W20-3	W3-4	R4-7a	R3-1	R11-4
C9A(CA)	W4-2 RT	C30(CA)	W20-3	W20-2	W3-4	R4-7a	R3-1	R11-2

RACE NOTES:
1. RACE INFORMATION SIGNS SHALL BE PLACED ALONG ROUTE A MINIMUM 2 WEEKS PRIOR TO EVENT.
2. TEMP. NO PARKING SIGNS SHALL BE PLACED ALONG RACE ROUTE 72 HRS PRIOR TO EVENT

TRAFFIC CONTROL PLAN

UNINCORPORATED COUNTY AREA

DRAWN BY: JAIME BORRUEL JR.
HUDSON SAFE-T-LITE
777 Gable Way
El Cajon, CA 92020
PH: 619-441-3644 FAX: 619-441-3652

CITY: _____

DATE DRAWN: FEBRUARY 2016
SCALE: NO SCALE
DRAWING NUMBER: SHEET 12 OF 24

LEGEND: CONE ● SIGN ■ WORK AREA [Hatched] TRAFFIC DIRECTION ⇄ FLASHING ARROW SIGN (FAS) [Square with arrow] SIGNALIZED INTERSECTION (S) FLAGGER [Stick figure]

THOMAS BROS.: _____ POSTED SPEED LIMIT: _____ TAPER LENGTH: _____ SIGN SPACING: _____ CONE SPACING: _____

TYPE II BARRICADE [I] TEMPORARY NO PARKING [TNP]

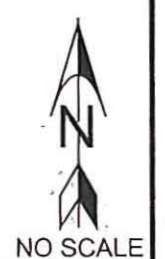
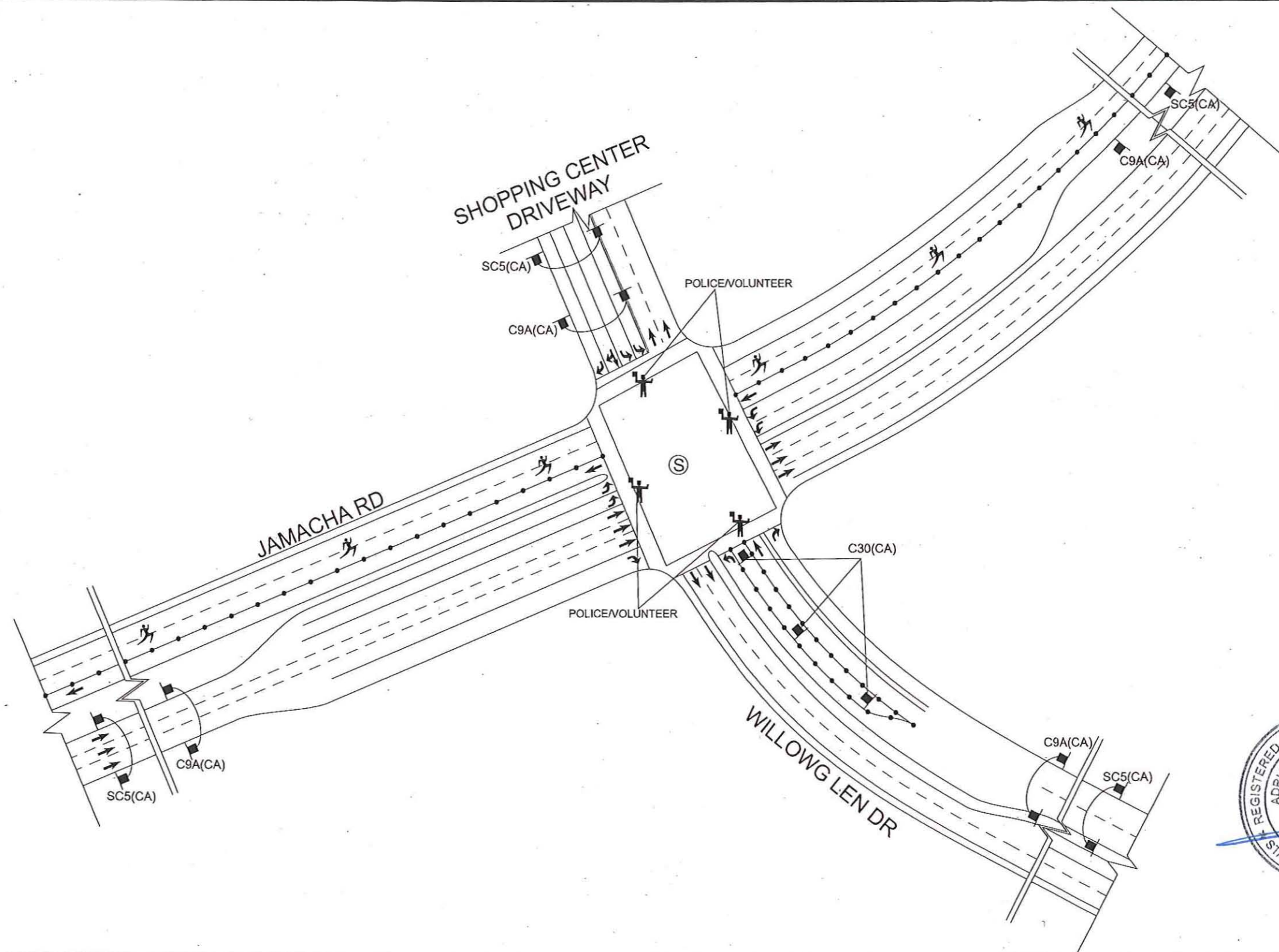

TYPICAL CONSTRUCTION SIGNS

RACE NOTES:
 1. RACE INFORMATION SIGNS SHALL BE PLACED ALONG ROUTE A MINIMUM 2 WEEKS PRIOR TO EVENT.
 2. TEMP. NO PARKING SIGNS SHALL BE PLACED ALONG RACE ROUTE 72 HRS PRIOR TO EVENT

TRAFFIC CONTROL PLAN

UNINCORPORATED COUNTY AREA

DRAWN BY: JAIME BORRUEL Jr.
 HUDSON SAFE-T-LITE
 777 Gable Way
 El Cajon, CA 92020
 PH: 619-441-3644 FAX: 619-441-3652

CITY: _____

DATE DRAWN: **FEBRUARY 2016** SCALE: NO SCALE DRAWING NUMBER: SHEET 13 OF 24

THOMAS BROS.:	POSTED SPEED LIMIT:	TAPER LENGTH:	SIGN SPACING:	CONE SPACING:
---------------	---------------------	---------------	---------------	---------------

NOTES:
 CONES TO BE SPACED AT 25' THROUGH
 THE CENTER OF THE RUNNING LANE TO SEPARATE
 RUNNERS IN EACH DIRECTION THROUGHOUT
 ENTIRE COURSE

SEE SHEETS 9 THRU 12 FOR
 TYPICAL INTERSECTION CROSSING DETAILS

SEE SHEET 4 FOR BIKE LANE CLOSURE

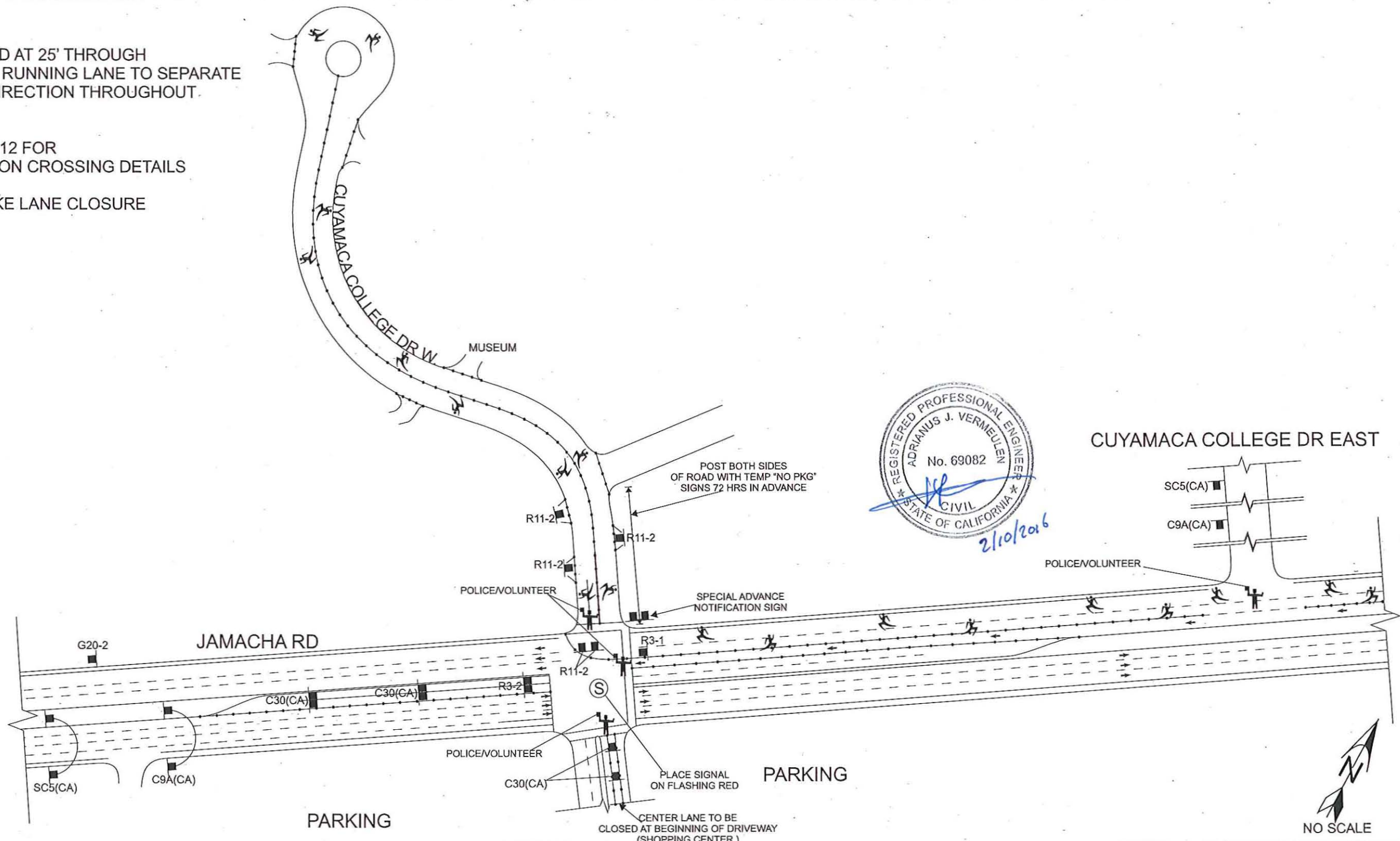

CUYAMACA COLLEGE DR EAST

TYPICAL CONSTRUCTION SIGNS

RACE NOTES:
 1. RACE INFORMATION SIGNS SHALL BE PLACED ALONG ROUTE A MINIMUM
 2 WEEKS PRIOR TO EVENT.
 2. TEMP. NO PARKING SIGNS SHALL BE PLACED ALONG RACE ROUTE 72 HRS
 PRIOR TO EVENT

TRAFFIC CONTROL PLAN

UNINCORPORATED COUNTY AREA

DRAWN BY: JAIME BORRUEL JR.
 HUDSON SAFE-T-LITE
 777 Gable Way
 El Cajon, CA 92020
 PH: 619-441-3644 FAX: 619-441-3652

CITY: _____

DATE DRAWN: **FEBRUARY 2016** SCALE: NO SCALE DRAWING NUMBER: SHEET 14 OF 24

LEGEND: CONE ●	SIGN ■	WORK AREA [diagonal lines]	TRAFFIC DIRECTION ⇄	FLASHING ARROW SIGN (FAS) [arrow with dots]	SIGNALIZED INTERSECTION (S) (C)	FLAGGER [stick figure]	TYPE II BARRICADE [I]	TEMPORARY NO PARKING [TNP]
THOMAS BROS.:	POSTED SPEED LIMIT:	TAPER LENGTH:	SIGN SPACING:	CONE SPACING:				

JAMACHA RD TYPICAL INTERSECTION CROSSING "A" (NON SIGNALIZED)

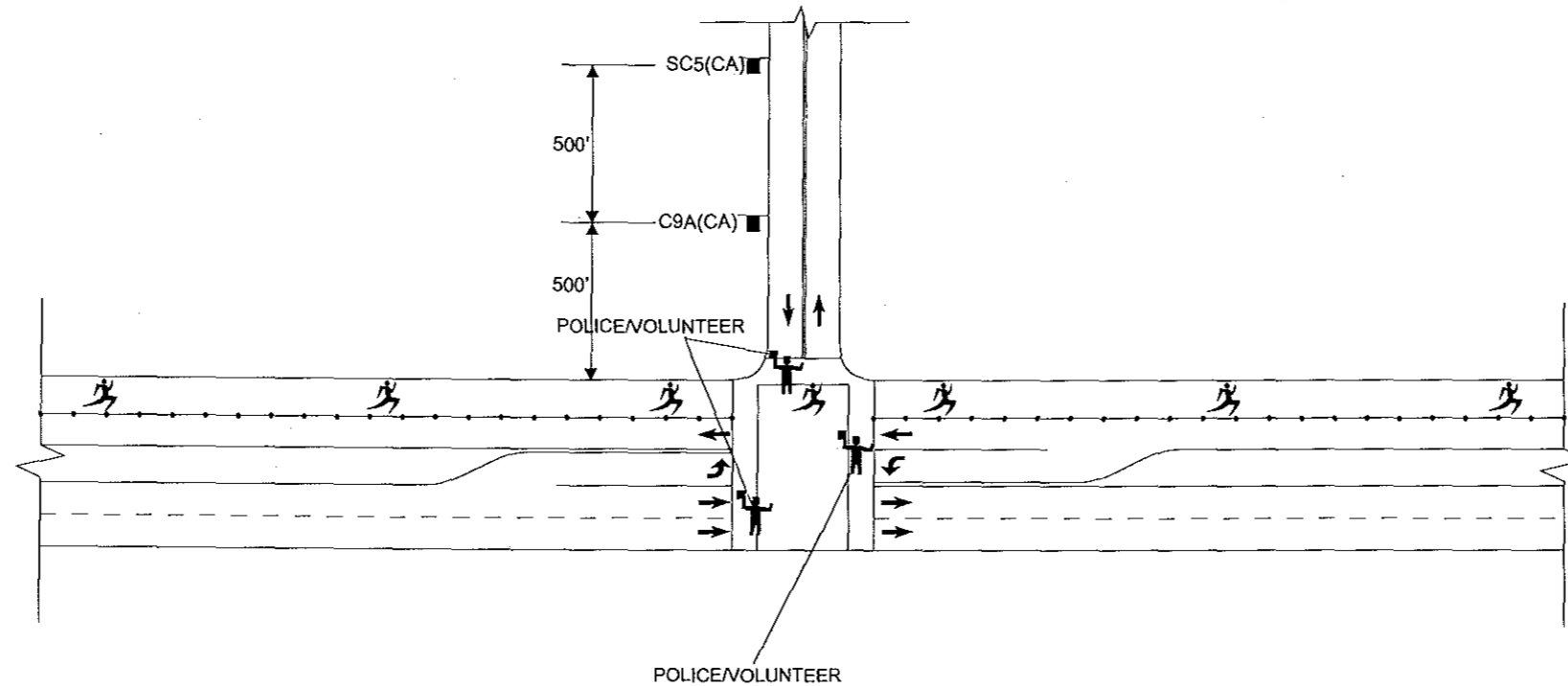

TYPICAL CONSTRUCTION SIGNS

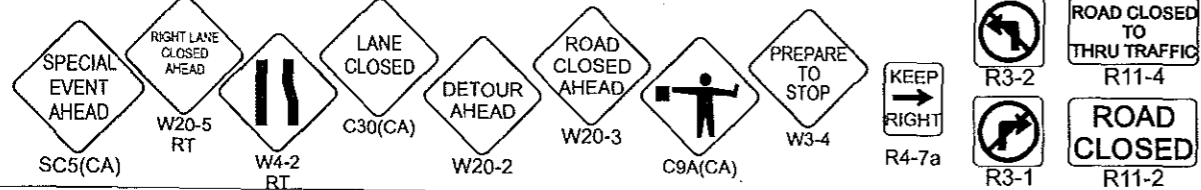

RACE NOTES:
 1. RACE INFORMATION SIGNS SHALL BE PLACED ALONG ROUTE A MINIMUM 2 WEEKS PRIOR TO EVENT.
 2. TEMP. NO PARKING SIGNS SHALL BE PLACED ALONG RACE ROUTE 72 HRS PRIOR TO EVENT

TRAFFIC CONTROL PLAN

CITY OF EL CAJON
UNINCORPORATED COUNTY AREA

DRAWN BY: JAIME BORRUEL Jr.

HUDSON SAFE-T-LITE
777 Gable Way
El Cajon, CA 92020

CITY

PH: 619-441-3644 FAX: 619-441-3652

DATE DRAWN:

SCALE:

DRAWING NUMBER:

FEBRUARY 2016

NO SCALE

SHEET 15 OF 24

LEGEND: CONE ●	SIGN ■	WORK AREA ▨	TRAFFIC DIRECTION ← →	FLASHING ARROW SIGN (FAS) ⚡	SIGNALIZED INTERSECTION Ⓢ	FLAGGER ■	TYPE II BARRICADE I	TEMPORARY NO PARKING ← TNP →
THOMAS BROS.:	POSTED SPEED LIMIT:	TAPER LENGTH:	SIGN SPACING:	CONES SPACING:				

JAMACHA RD TYPICAL INTERSECTION CROSSING "B" (NON SIGNALIZED)

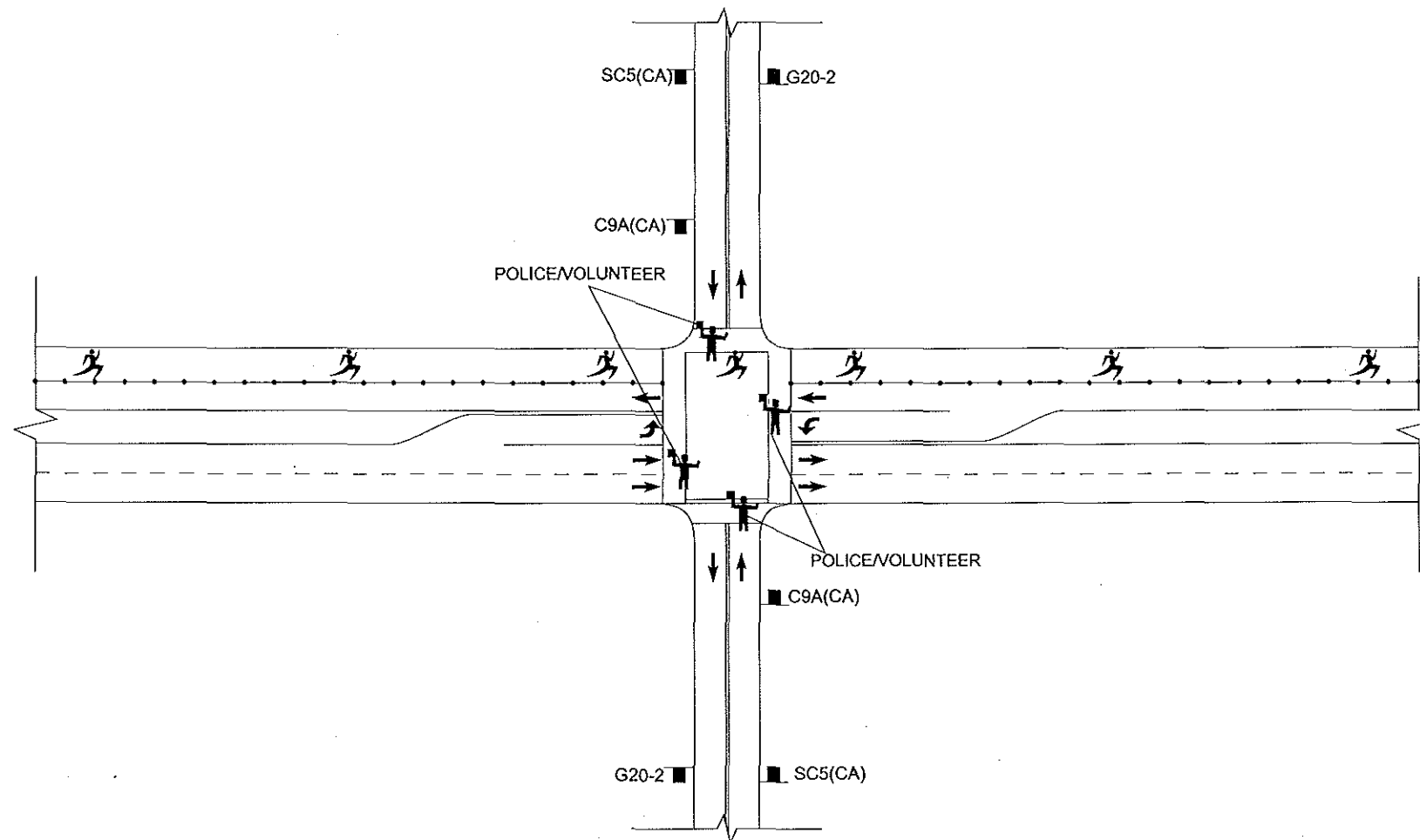

TYPICAL CONSTRUCTION SIGNS

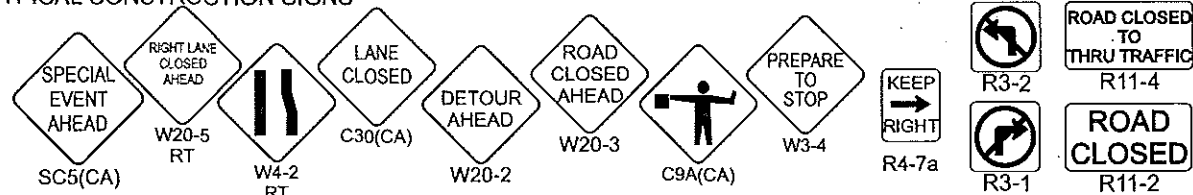

RACE NOTES:

1. RACE INFORMATION SIGNS SHALL BE PLACED ALONG ROUTE A MINIMUM 2 WEEKS PRIOR TO EVENT.
2. TEMP. NO PARKING SIGNS SHALL BE PLACED ALONG RACE ROUTE 72 HRS PRIOR TO EVENT

TRAFFIC CONTROL PLAN

CITY OF EL CAJON

UNINCORPORATED COUNTY AREA

DRAWN BY: JAIME BORRUEL Jr.

HUDSON SAFE-T-LITE
777 Gable Way
El Cajon, CA 92020

CITY

PH: 619-441-3644 FAX: 619-441-3652

DATE DRAWN:

SCALE:

DRAWING NUMBER:

FEBRUARY 2016

NO SCALE

SHEET 16 OF 24

LEGEND: CONE ●	SIGN ■	WORK AREA ▨	TRAFFIC DIRECTION ⇄	FLASHING ARROW SIGN (FAS) ⚡	SIGNALIZED INTERSECTION Ⓢ	FLAGGER ■	TYPE II BARRICADE I	TEMPORARY NO PARKING TNP ⚡
THOMAS BROS.:	POSTED SPEED LIMIT:	TAPER LENGTH:	SIGN SPACING:	CONE SPACING:				

JAMACHA RD TYPICAL INTERSECTION CROSSING "C" (SIGNALIZED)

USE AT THE FOLLOWING INTERSECTIONS

- JAMACHA RD / FURY LN
- JAMACHA RD / HILTON HEAD RD
- JAMACHA RD / CALLE ALBARA
- JAMACHA RD / HILLSDALE RD

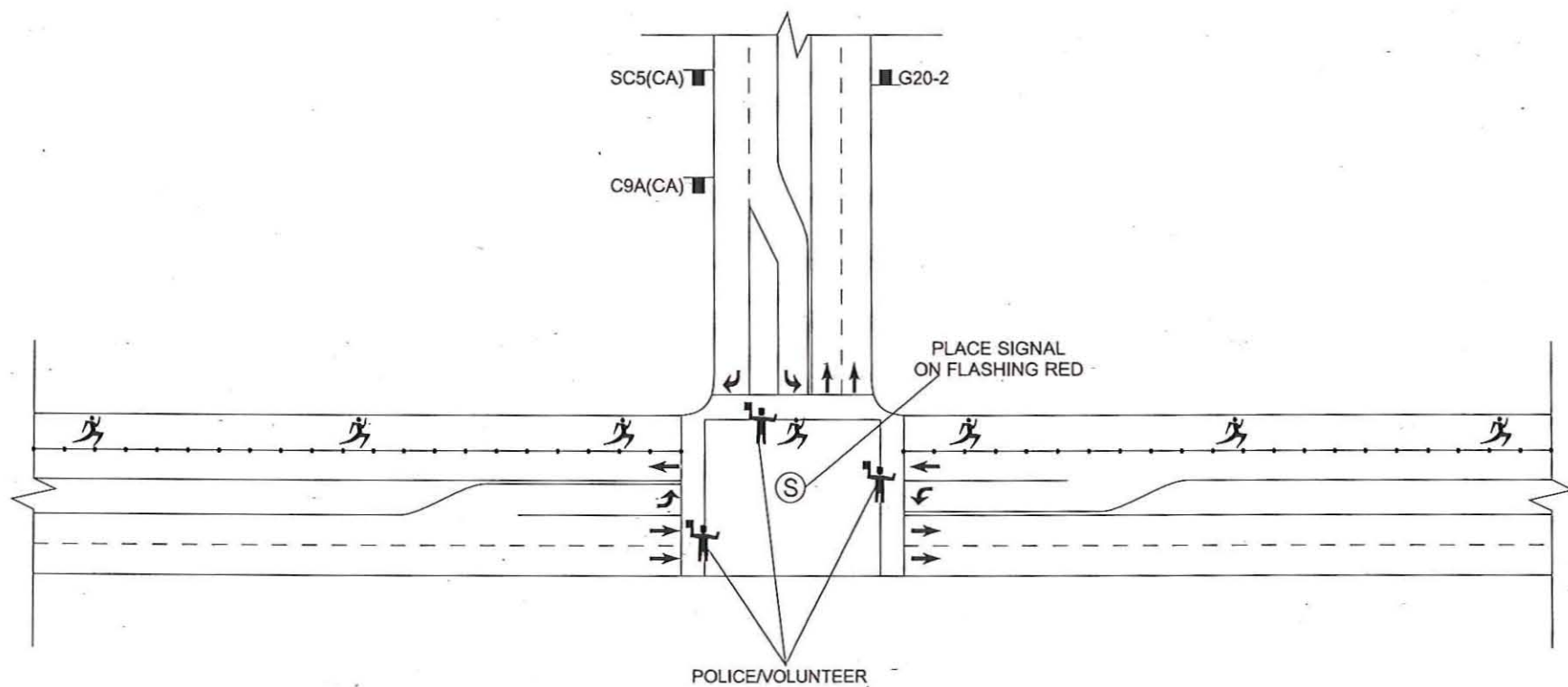

NOTE:
SIGNALS SHALL BE PLACED INTO FLASHING RED OPERATION BY THE POLICE DEPARTMENT AND RESET BACK INTO NORMAL OPERATION AFTER THE EVENT.

TYPICAL CONSTRUCTION SIGNS

SC5(CA)	W20-5 RT	C30(CA)	W20-2	W20-3	W3-4	R4-7a	R3-2	R11-4

RACE NOTES:
1. RACE INFORMATION SIGNS SHALL BE PLACED ALONG ROUTE A MINIMUM 2 WEEKS PRIOR TO EVENT.
2. TEMP. NO PARKING SIGNS SHALL BE PLACED ALONG RACE ROUTE 72 HRS PRIOR TO EVENT

TRAFFIC CONTROL PLAN

CITY OF EL CAJON
UNINCORPORATED COUNTY AREA

DRAWN BY: JAIME BORRUEL Jr.
HUDSON SAFE-T-LITE
777 Gable Way
El Cajon, CA 92020
PH: 619-441-3644 FAX: 619-441-3652

DATE DRAWN: **FEBRUARY 2016** SCALE: NO SCALE DRAWING NUMBER: SHEET 17 OF 24

LEGEND: CONE ● SIGN ■ WORK AREA [hatched] TRAFFIC DIRECTION ←→ FLASHING ARROW SIGN (FAS) [arrow with wavy lines] SIGNALIZED INTERSECTION (S) FLAGGER [stick figure] TYPE II BARRICADE [I] TEMPORARY NO PARKING [TNP]

THOMAS BROS.:	POSTED SPEED LIMIT:	TAPER LENGTH:	SIGN SPACING:	CONE SPACING:
---------------	---------------------	---------------	---------------	---------------

JAMACHA RD TYPICAL INTERSECTION CROSSING "D" (SIGNALIZED)

USE AT THE FOLLOWING INTERSECTIONS

- JAMACHA RD / GUSTAVO ST
- JAMACHA RD / GRANITE HILLS DR
- JAMACHA RD / LEXINGTON AVE
- JAMACHA RD / WASHINGTON AVE

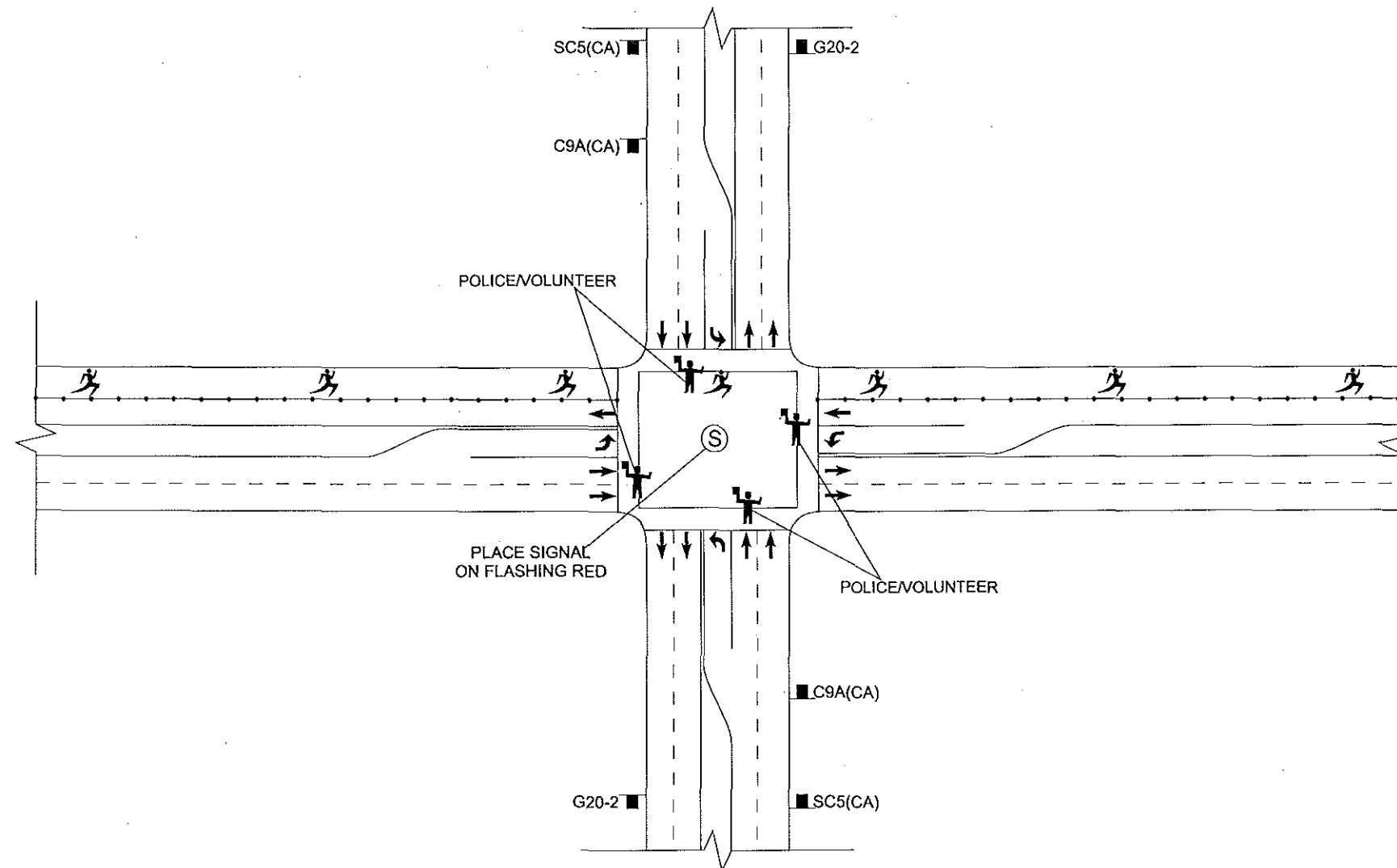

NOTE:
SIGNALS SHALL BE PLACED INTO FLASHING RED OPERATION BY THE POLICE DEPARTMENT AND RESET BACK INTO NORMAL OPERATION AFTER THE EVENT.

TYPICAL CONSTRUCTION SIGNS

SC5(CA)	W20-5 RT	W4-2 RT	C30(CA)	W20-2	W20-3	C9A(CA)	W3-4	R4-7a	R3-2	R11-4
									R3-1	R11-2

RACE NOTES:

1. RACE INFORMATION SIGNS SHALL BE PLACED ALONG ROUTE A MINIMUM 2 WEEKS PRIOR TO EVENT.
2. TEMP. NO PARKING SIGNS SHALL BE PLACED ALONG RACE ROUTE 72 HRS PRIOR TO EVENT

TRAFFIC CONTROL PLAN

CITY OF EL CAJON
UNINCORPORATED COUNTY AREA

DRAWN BY: JAIME BORRUEL Jr.

HUDSON SAFE-T-LITE
777 Gable Way
El Cajon, CA 92020

PH: 619-441-3644 FAX: 619-441-3652

DATE DRAWN:

SCALE:

DRAWING NUMBER:

FEBRUARY 2016

NO SCALE

SHEET 18 OF 24

LEGEND: CONE ● SIGN ■ WORK AREA TRAFFIC DIRECTION FLASHING ARROW SIGN (FAS) SIGNALIZED INTERSECTION (S) FLAGGER TYPE II BARRICADE I TEMPORARY NO PARKING TNP

THOMAS BROS.:	POSTED SPEED LIMIT:	TAPER LENGTH:	SIGN SPACING:	CONE SPACING:	
---------------	---------------------	---------------	---------------	---------------	--

MAIN ST TYPICAL INTERSECTION CROSSING "E" (NON SIGNALIZED)

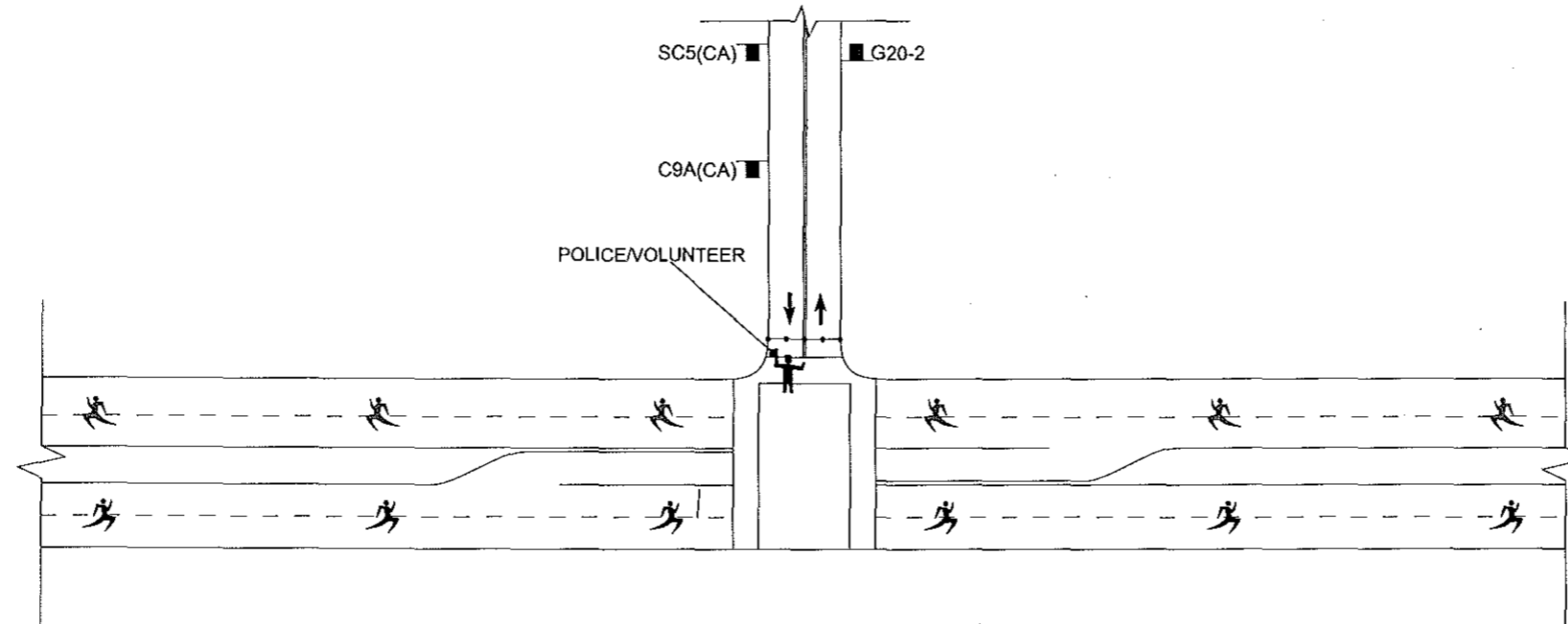

TYPICAL CONSTRUCTION SIGNS

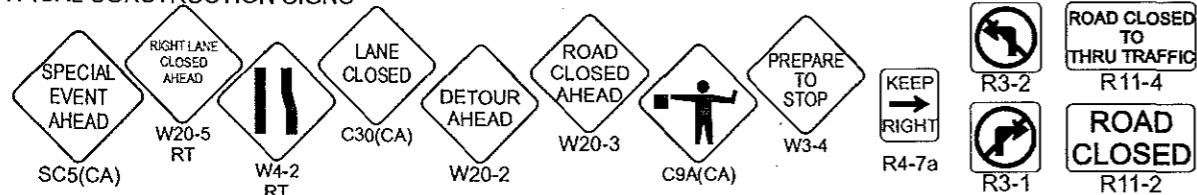

RACE NOTES:
 1. RACE INFORMATION SIGNS SHALL BE PLACED ALONG ROUTE A MINIMUM 2 WEEKS PRIOR TO EVENT.
 2. TEMP. NO PARKING SIGNS SHALL BE PLACED ALONG RACE ROUTE 72 HRS PRIOR TO EVENT

TRAFFIC CONTROL PLAN

CITY OF EL CAJON

DRAWN BY: JAIME BORRUEL Jr.
 HUDSON SAFE-T-LITE
 777 Gable Way
 El Cajon, CA 92020

CITY

PH: 619-441-3644 FAX: 619-441-3652

DATE DRAWN:
FEBRUARY 2016

SCALE:
 NO SCALE

DRAWING NUMBER:
 SHEET 19 OF 24

LEGEND: CONE ● SIGN ■ WORK AREA TRAFFIC DIRECTION FLASHING ARROW SIGN (FAS) SIGNALIZED INTERSECTION FLAGGER TYPE II BARRICADE TEMPORARY NO PARKING	THOMAS BROS.:	POSTED SPEED LIMIT:	TAPER LENGTH:	SIGN SPACING:	CONE SPACING:
---	---------------	---------------------	---------------	---------------	---------------

MAIN ST TYPICAL INTERSECTION CROSSING "F" (NON SIGNALIZED)

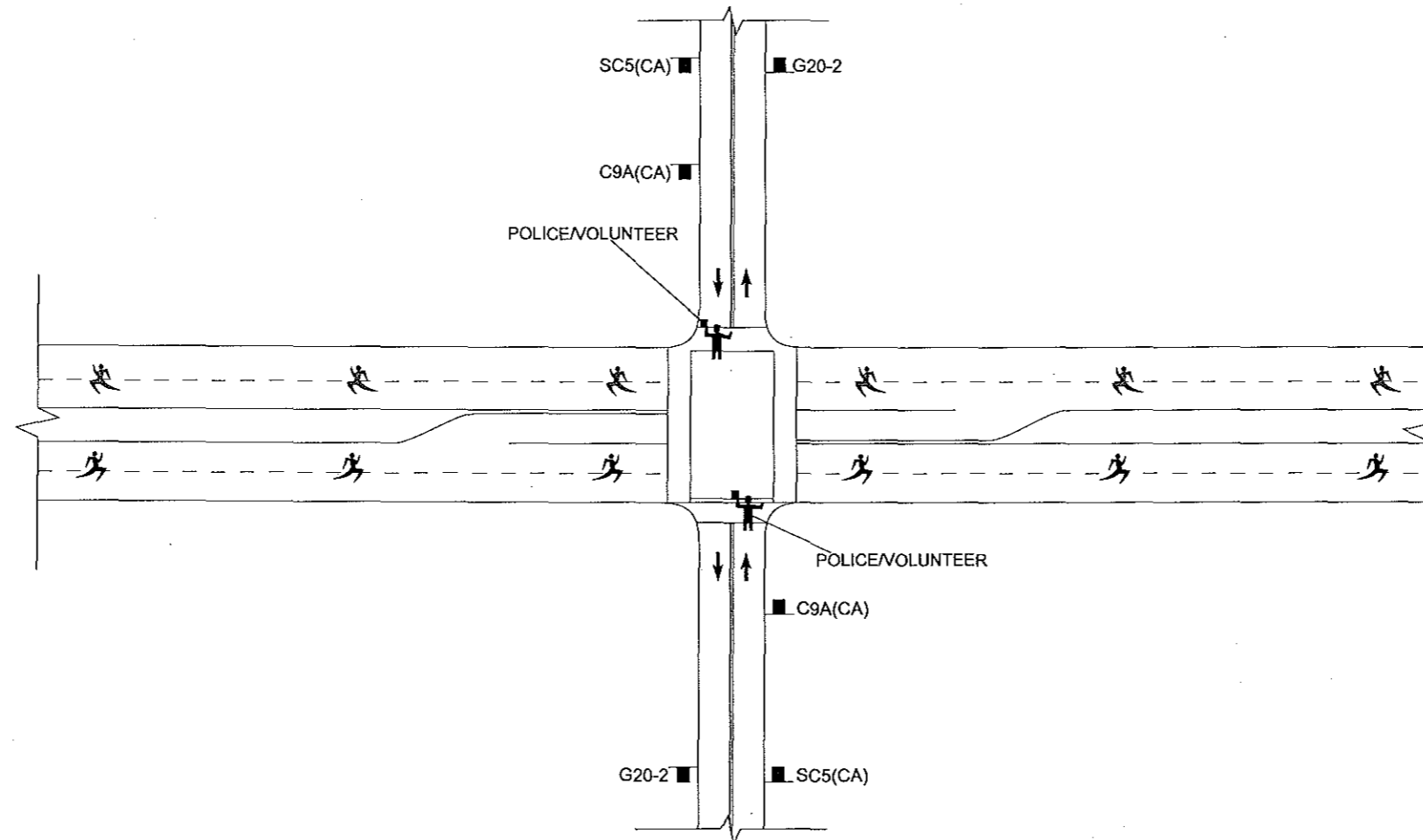

TYPICAL CONSTRUCTION SIGNS

SC5(CA)	W20-5 RT	W4-2 RT	C30(CA)	W20-2	W20-3	C9A(CA)	W3-4	R4-7a	R3-2	R11-4
									R3-1	R11-2

RACE NOTES:

1. RACE INFORMATION SIGNS SHALL BE PLACED ALONG ROUTE A MINIMUM 2 WEEKS PRIOR TO EVENT.
2. TEMP. NO PARKING SIGNS SHALL BE PLACED ALONG RACE ROUTE 72 HRS PRIOR TO EVENT

TRAFFIC CONTROL PLAN

CITY OF EL CAJON

DRAWN BY: JAIME BORRUEL Jr.

HUDSON SAFE-T-LITE
777 Gable Way
El Cajon, CA 92020

CITY

PH: 619-441-3644 FAX: 619-441-3652

DATE DRAWN:

FEBRUARY 2016

SCALE:

NO SCALE

DRAWING NUMBER:

SHEET 20 OF 24

LEGEND: CONE ●	SIGN ■	WORK AREA	TRAFFIC DIRECTION	FLASHING ARROW SIGN (FAS)	SIGNALIZED INTERSECTION	FLAGGER	TYPE II BARRICADE	TEMPORARY NO PARKING
THOMAS BROS.:	POSTED SPEED LIMIT:	TAPER LENGTH:	SIGN SPACING:	CONE SPACING:				

MAIN ST TYPICAL INTERSECTION CROSSING "G" (SIGNALIZED)

USE AT THE FOLLOWING INTERSECTIONS

- E. MAIN ST / BALLARD ST
- E. MAIN ST / ANZA ST
- E. MAIN ST / LINCOLN AVE
- E. MAIN ST / SULZFELD WY

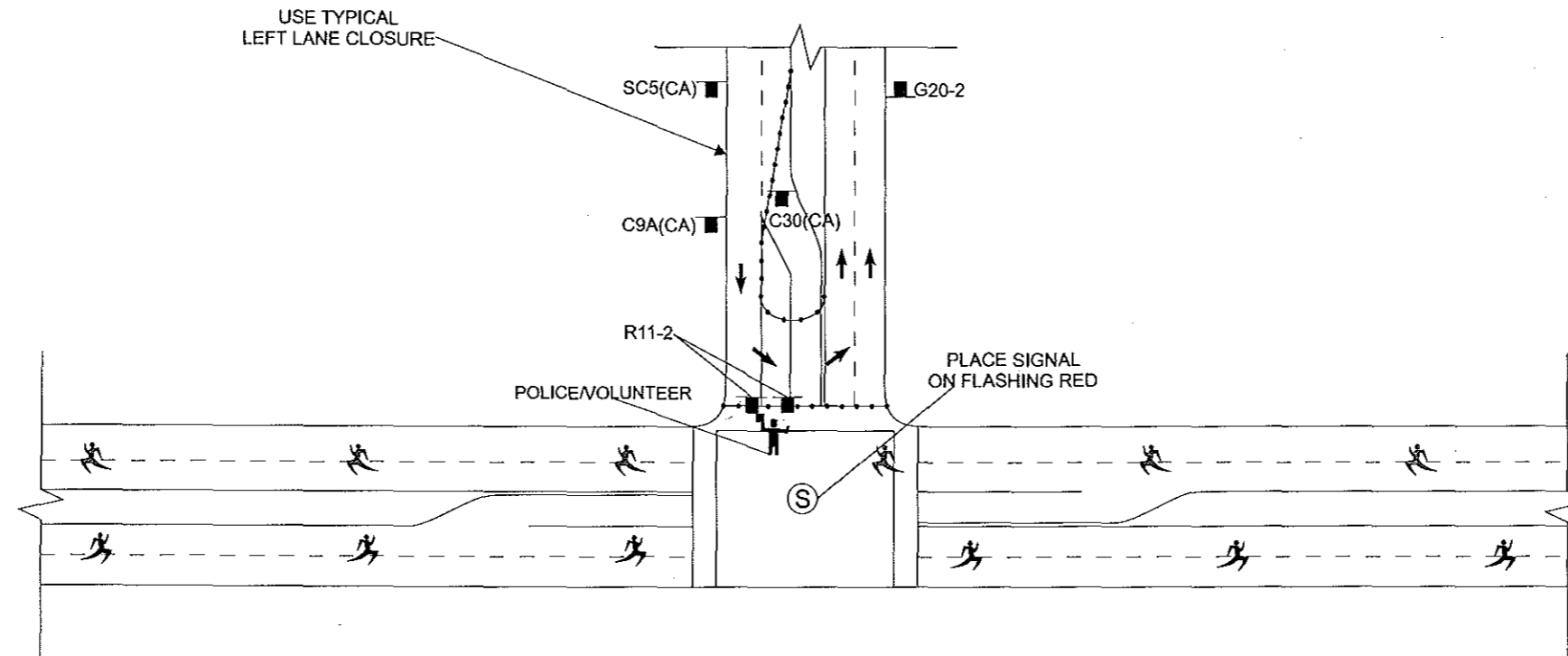

NOTE:
SIGNALS SHALL BE PLACED INTO FLASHING RED OPERATION BY THE POLICE DEPARTMENT AND RESET BACK INTO NORMAL OPERATION AFTER THE EVENT.

TYPICAL CONSTRUCTION SIGNS

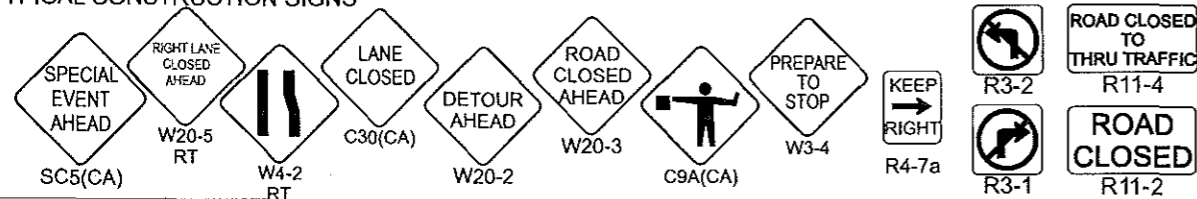

RACE NOTES:

1. RACE INFORMATION SIGNS SHALL BE PLACED ALONG ROUTE A MINIMUM 2 WEEKS PRIOR TO EVENT.
2. TEMP. NO PARKING SIGNS SHALL BE PLACED ALONG RACE ROUTE 72 HRS PRIOR TO EVENT

TRAFFIC CONTROL PLAN

CITY OF EL CAJON

DRAWN BY: JAIME BORRUEL JR.

HUDSON SAFE-T-LITE
777 Gable Way
El Cajon, CA 92020

PH: 619-441-3644 FAX: 619-441-3652

DATE DRAWN:

FEBRUARY 2016

SCALE:

NO SCALE

DRAWING NUMBER:

SHEET 21 OF 24

THOMAS BROS.:	POSTED SPEED LIMIT:	TAPER LENGTH:	SIGN SPACING:	CONE SPACING:
---------------	---------------------	---------------	---------------	---------------

MAIN ST TYPICAL INTERSECTION CROSSING "H" (SIGNALIZED)

USE AT THE FOLLOWING INTERSECTIONS

- E. MAIN ST / FIRST ST
- E. MAIN ST / MOLLISON AVE
- E. MAIN ST / AVOCADO AVE
- E. MAIN ST / CLAYDELLE AVE
- E. MAIN ST / MAGNOLIA AVE

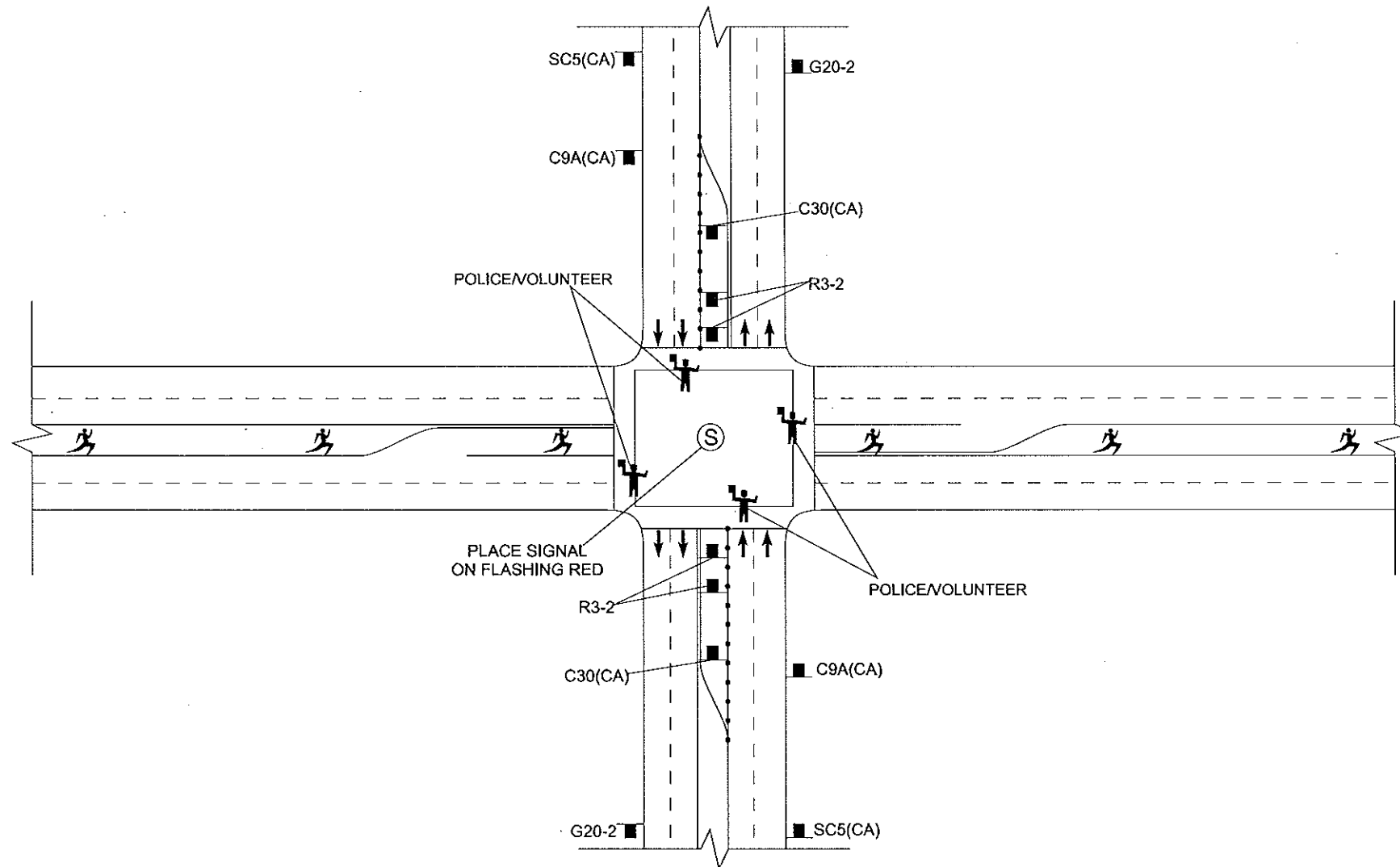

NOTE:
SIGNALS SHALL BE PLACED INTO FLASHING RED OPERATION BY THE POLICE DEPARTMENT AND RESET BACK INTO NORMAL OPERATION AFTER THE EVENT.

TYPICAL CONSTRUCTION SIGNS

SC5(CA)	W20-5 RT	C30(CA)	W20-2	W20-3	W3-4	R4-7a	R11-4	R11-2

RACE NOTES:

1. RACE INFORMATION SIGNS SHALL BE PLACED ALONG ROUTE A MINIMUM 2 WEEKS PRIOR TO EVENT.
2. TEMP. NO PARKING SIGNS SHALL BE PLACED ALONG RACE ROUTE 72 HRS PRIOR TO EVENT

TRAFFIC CONTROL PLAN

CITY OF EL CAJON

DRAWN BY: JAIME BORRUEL Jr.

HUDSON SAFE-T-LITE
777 Gable Way
El Cajon, CA 92020

CITY

PH: 619-441-3644 FAX: 619-441-3652

DATE DRAWN:

SCALE:

DRAWING NUMBER:

FEBRUARY 2016

NO SCALE

SHEET 22 OF 24

LEGEND: CONE ● SIGN ■ WORK AREA TRAFFIC DIRECTION FLASHING ARROW SIGN (FAS) SIGNALIZED INTERSECTION (S) FLAGGER TYPE II BARRICADE I TEMPORARY NO PARKING

THOMAS BROS.:	POSTED SPEED LIMIT:	TAPER LENGTH:	SIGN SPACING:	CONE SPACING:			
---------------	---------------------	---------------	---------------	---------------	--	--	--

MAIN ST TYPICAL INTERSECTION CROSSING "I" (NON SIGNALIZED)

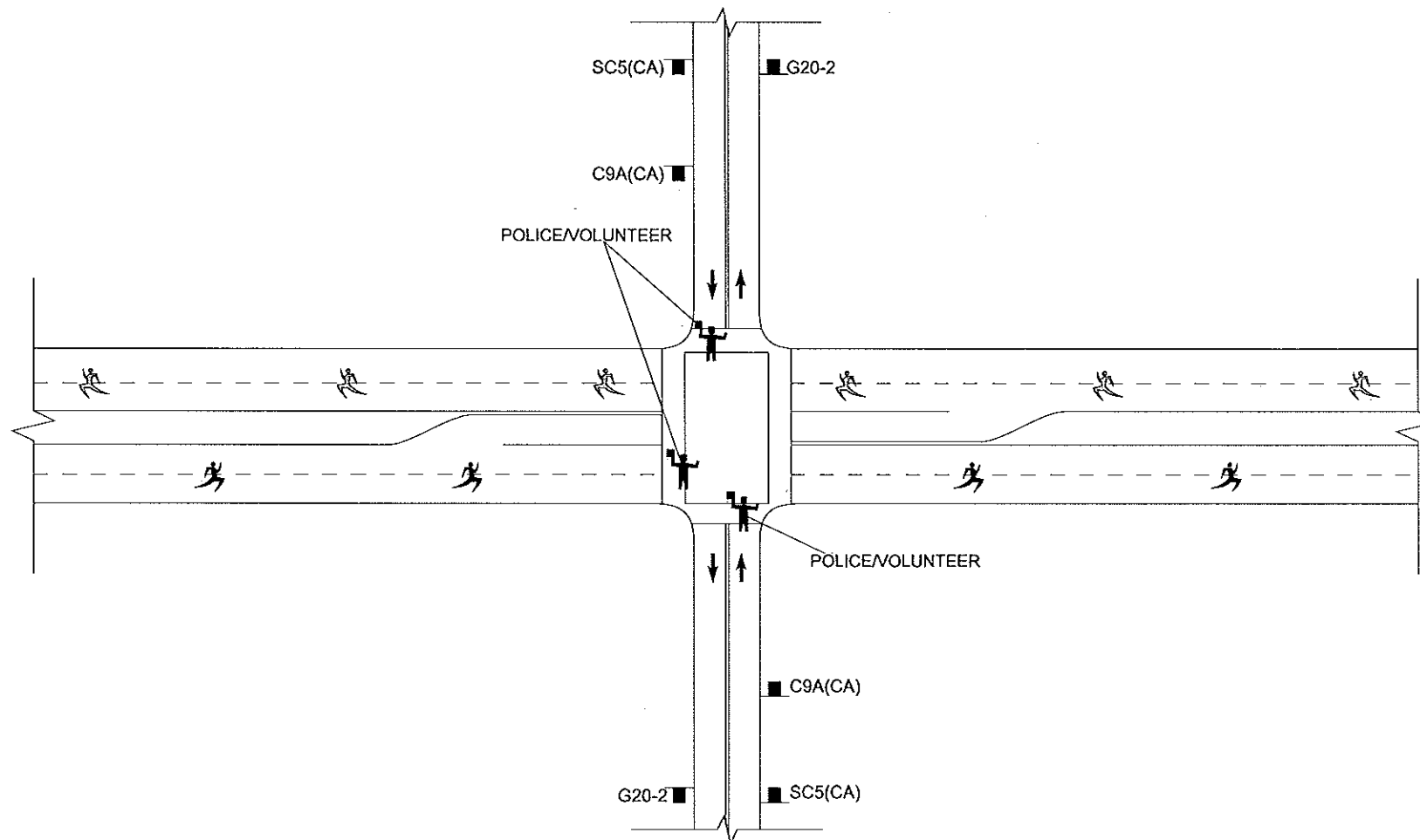

TYPICAL CONSTRUCTION SIGNS

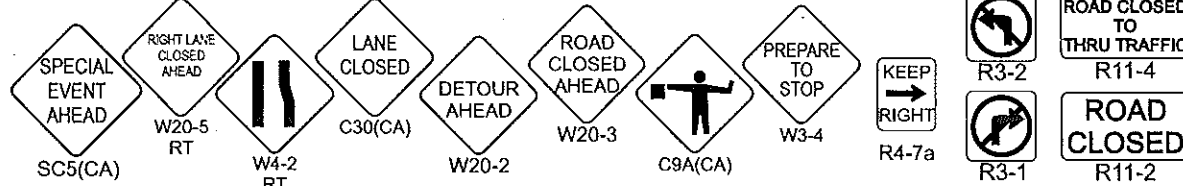

RACE NOTES:

1. RACE INFORMATION SIGNS SHALL BE PLACED ALONG ROUTE A MINIMUM 2 WEEKS PRIOR TO EVENT.
2. TEMP. NO PARKING SIGNS SHALL BE PLACED ALONG RACE ROUTE 72 HRS PRIOR TO EVENT

TRAFFIC CONTROL PLAN

CITY OF EL CAJON

DRAWN BY: JAIME BORRUEL Jr.

HUDSON SAFE-T-LITE
777 Gable Way
El Cajon, CA 92020

CITY

PH: 619-441-3644 FAX: 619-441-3652

DATE DRAWN:

SCALE:

DRAWING NUMBER:

FEBRUARY 2016

NO SCALE

SHEET 23 OF 24

LEGEND: CONE ● SIGN ■ WORK AREA ▨ TRAFFIC DIRECTION ⇄ FLASHING ARROW SIGN (FAS) ⚡ SIGNALIZED INTERSECTION Ⓢ FLAGGER ■ TYPE II BARRICADE I TEMPORARY NO PARKING ←-INP->

THOMAS BROS.:	POSTED SPEED LIMIT:	TAPER LENGTH:	SIGN SPACING:	CONE SPACING:	
---------------	---------------------	---------------	---------------	---------------	--

MAIN ST TYPICAL INTERSECTION CROSSING "J" (NON SIGNALIZED)

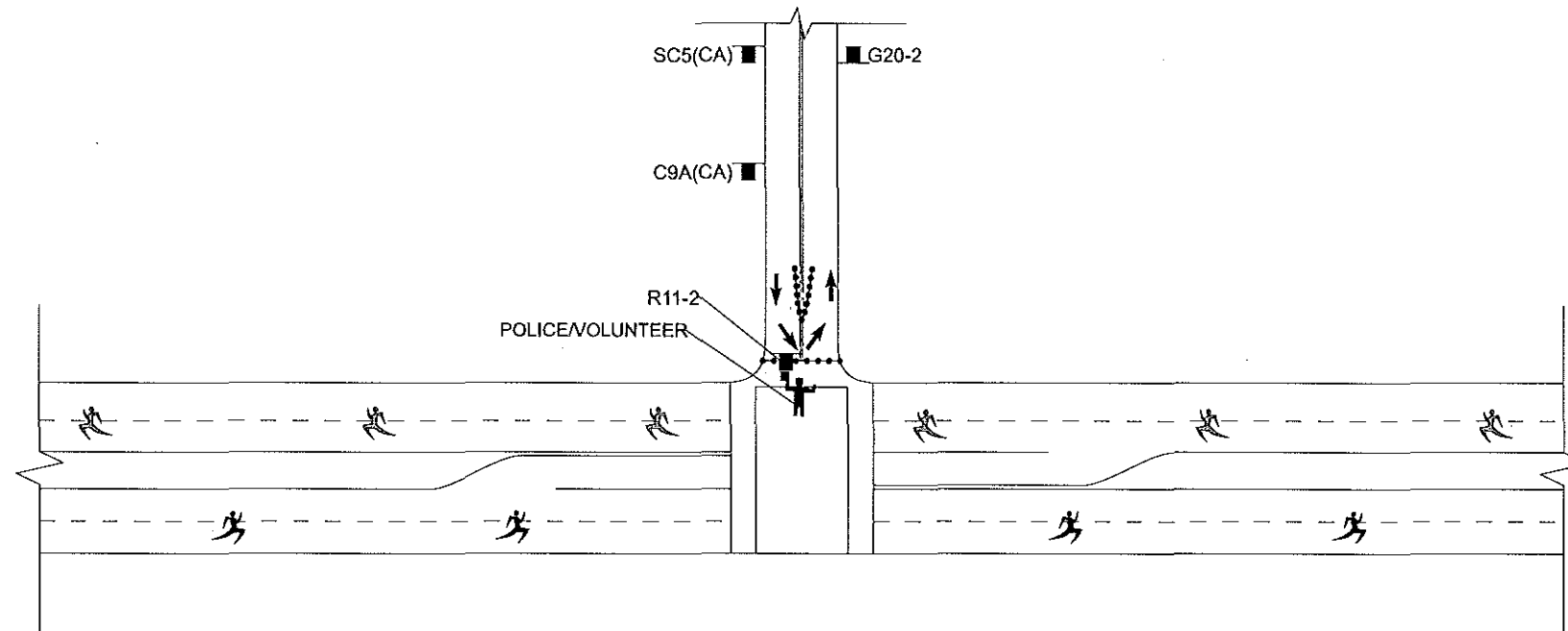

TYPICAL CONSTRUCTION SIGNS

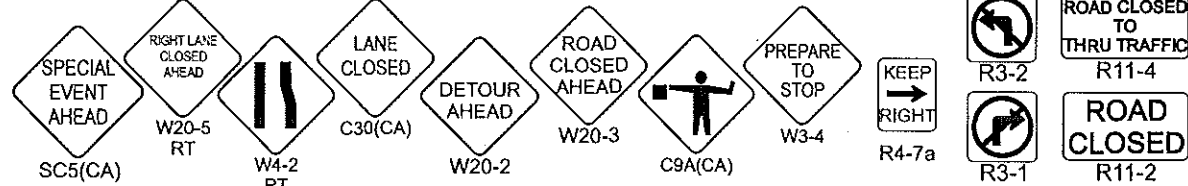

RACE NOTES:

1. RACE INFORMATION SIGNS SHALL BE PLACED ALONG ROUTE A MINIMUM 2 WEEKS PRIOR TO EVENT.
2. TEMP. NO PARKING SIGNS SHALL BE PLACED ALONG RACE ROUTE 72 HRS PRIOR TO EVENT

TRAFFIC CONTROL PLAN

CITY OF EL CAJON

DRAWN BY: JAIME BORRUEL Jr.

HUDSON SAFE-T-LITE
777 Gable Way
El Cajon, CA 92020

CITY

PH: 619-441-3644 FAX: 619-441-3652

DATE DRAWN:

FEBRUARY 2016

SCALE:

NO SCALE

DRAWING NUMBER:

SHEET 24 OF 24

LEGEND: CONE ● SIGN ■ WORK AREA ▨ TRAFFIC DIRECTION ⇄ FLASHING ARROW SIGN (FAS) ⚡ SIGNALIZED INTERSECTION Ⓢ FLAGGER ■ TYPE II BARRICADE I TEMPORARY NO PARKING ⚡ TNP

THOMAS BROS.:	POSTED SPEED LIMIT:	TAPER LENGTH:	SIGN SPACING:	CONE SPACING:			
---------------	---------------------	---------------	---------------	---------------	--	--	--

City Clerk Date Stamp

RECEIVED OFFICE OF
CITY CLERK
EL CAJON CA

2018 FEB -8 P 12: 30

City of El Cajon Agenda Report

MEETING: Feb. 13, 2018

ITEM NO: 4.1

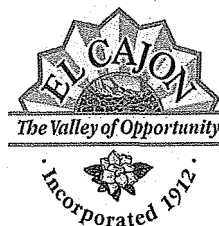

TO: Mayor Wells, Mayor Pro Tem Kendrick,
Councilmembers Goble, Kalasho and McClellan

FROM: Nahid Razi, Purchasing Agent

SUBJECT: Award of Bid No. 021-18, Sewer & Storm Drain Repair & Replacement
(WW3519)

RECOMMENDATION: That the City Council adopts the next resolution in order awarding the bid to the sole responsive, responsible bidder, Burtech Pipeline, Inc., in the amount of \$2,627,759.00 for the base bid and Additive Alternate No. 3.

BACKGROUND: On October 10, 2017, the City Council approved the plans and specifications for the repair and/or replacement of corrugated metal storm drain pipes, vitrified clay pipes, and junction structures throughout City limits. One response was received and opened at 2:00 p.m. on January 16, 2018. The Purchasing Division contacted various general contractors that had downloaded the bid package to inquire as to why they did not respond to the bid. The majority of those contacted stated that they had full schedules and could not accommodate this project. Other contractors stated that the scope of lining work was outside of their realm of services.

The California Public Contract Code allows the City to specify which award method will be utilized to determine the lowest bid. In accordance with Addendum No. 3 to the bid specifications, the lowest bid shall be determined by the lowest base bid plus the sum of additive alternates. This language does not preclude the City from adding or deducting any additive items after the lowest responsible bidder has been determined. After examining the bid, Additive Alternate No. 3 (Grape Street Easement Storm Drain) shall be included in the award.

The Purchasing Division, in concurrence with the Director of Public Works, recommends award of the bid to the sole responsive, responsible bidder, Burtech Pipeline, Inc., in the amount of \$2,627,759.00 (base bid of \$2,553,146.00 and Additive Alternate No. 3 of \$74,613.00). The summary of the bid is attached and the complete proposal is on file in the Purchasing Division.

FISCAL IMPACT: The fiscal impact of this project is \$2,627,759.00. Sufficient funds are available for this project in the City Wastewater Program Fund (WW3519).

PREPARED BY:

REVIEWED BY:

APPROVED BY:

Nahid Razi
PURCHASING AGENT

Dirk Epperson
DIRECTOR OF
PUBLIC WORKS

Douglas Williford
CITY MANAGER

BID SUMMARY - BID NO. 021-18

BIDDER

BASE BID AMOUNT

Burtech Pipeline, Inc. (Encinitas, CA)

\$2,553,146.00 *

ENGINEER'S ESTIMATE

\$2,400,000.00

*** RECOMMEND AWARD**

Burtech Pipeline, Inc. Additive Alternates

Additive Alternate No. 1: Lincoln Avenue Storm Drain

\$57,190.00

Additive Alternate No. 2: East Main Street East of Mollison Storm Drain

\$125,270.00

Additive Alternate No. 3: Grape Street Easement Storm Drain

\$74,613.00*

Additive Alternate No. 4: Broadway/Third Street Storm Drain

\$113,198.00

RESOLUTION NO. -18

RESOLUTION AWARDING BID FOR
SEWER AND STORM DRAIN REPAIR AND REPLACEMENT
(Bid No. 021-18, Job No. WW3519)

WHEREAS, on October 10, 2017, the City Council approved the plans and specifications for the Sewer and Storm Drain Project and Replacement project (the "Project") to repair and/or replace corrugated metal storm drain pipes, vitrified clay pipes, and junction structures throughout City limits; and

WHEREAS, one (1) response was received and opened on January 16, 2018; and

WHEREAS, the California Public Contract Code allows the City to specify which award method will be utilized to determine the lowest bid, and in accordance with Addendum No. 3 to the bid specifications, the lowest bid shall be determined by the lowest base bid plus the sum of all additive alternates selected; and

WHEREAS, after examination of the sole bid, it was determined that Additive Alternate No. 3 (Grape Street Easement Storm Drain) should be included in the award; and

WHEREAS, the Purchasing Division, in concurrence with the Director of Public Works, recommends award of the bid, including Additive Alternate No. 3, to the sole responsive, responsible bidder; and

WHEREAS, the City Council believes it to be in the best interests of the City to award the contract to the sole responsive, responsible bidder as recommended by the Purchasing Division.

NOW, THEREFORE, BE IT RESOLVED BY THE CITY COUNCIL OF THE CITY OF EL CAJON AS FOLLOWS:

1. The above recitals are true and correct, and are the findings of the City Council.

2. The City Council hereby awards the bid for the Sewer and Storm Drain Project and Replacement project to:

Burtech Pipeline, Inc.

in the amount of \$2,627,759.00 (consisting of its base bid amount of \$2,553,146.00 plus Additive Alternate No. 3 amount of \$74,613.00).

3. The Mayor and City Clerk are authorized and directed to execute a contract for said Project on behalf of the City of El Cajon.

City Clerk Date Stamp
RECEIVED OFFICE OF
CITY CLERK
EL CAJON CA
2018 FEB -7 A 10:38

City of El Cajon Agenda Report

MEETING: 2/13/18

ITEM NO: 6.1



TO: Mayor Pro Tem Kendrick, and Councilmembers
Goble, Kalasho and McClellan

FROM: Mayor Wells

SUBJECT: Council Activities Report

RECOMMENDATION: That the City Council accept and file the following report of Council/Mayor activities attended during the current agenda period.

BACKGROUND:

Government Code Section 53232.3(d) requires members of a legislative body to provide brief reports on meetings attended at the expense of the local agency at the next regular meeting of the legislative body.

REPORT:

Since the last City Council meeting, I have attended the following events on behalf of the City of El Cajon:

- January 24, 2018 - KPRZ Interview
- January 24, 2018 - Fletcher Hills Town Hall Meeting
- January 25, 2018 - Speaker at Foothills Middle School
- January 29, 2018 - Meeting w/ Gary Hendricks – El Cajon Rock Church
- January 30, 2018 - Speaker at Rotary Club Meeting
- January 30, 2018 - San Diego County Apartment Association Meeting
- February 1, 2018 - San Diego Association of Realtors Meeting
- February 2, 2018 - La Vida Real Retirement Community Bible Study Group
- February 5, 2018 - LAFCO Meeting
- February 5, 2018 - Citizen of the Year Luncheon
- February 6, 2018 - Meeting w/ San Ysidro Health
- February 7-9, 2018 - SANDAG Retreat
- February 9, 2018 - La Villa Real Retirement Community
- February 10, 2018 - Fletcher Hills Kiwanis – Breakfast Meeting
- February 13, 2018 - City Council Meeting(s)

I will be happy to answer any questions you may have.

SUBMITTED BY,

Bill Wells
Mayor

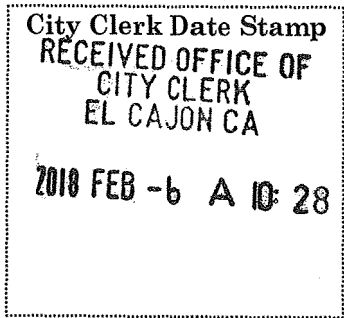

City of El Cajon Agenda Report

MEETING: 2/13/18

ITEM NO: 7.1



TO: Mayor Wells, Councilmembers Goble, Kalasho and McClellan

FROM: Mayor Pro Tem Kendrick

SUBJECT: Council Activities Report

RECOMMENDATION: That the City Council accept and file the following report of Council/Mayor activities attended during the current agenda period.

BACKGROUND:

Government Code Section 53232.3(d) requires members of a legislative body to provide brief reports on meetings attended at the expense of the local agency at the next regular meeting of the legislative body.

REPORT:

Since the last City Council meeting, I have attended the following events on behalf of the City of El Cajon:

- January 25, 2018 - Heartland Communication Facility Authority Meeting
- February 5, 2018 - Meeting w/ City Manager
- February 8, 2018 - Chuck Hansen's Celebration of Life
- February 13, 2018 - City Council Meeting(s)

I will be happy to answer any questions you may have.

SUBMITTED BY,

Gary Kendrick

 Gary Kendrick
 Mayor Pro Tem 

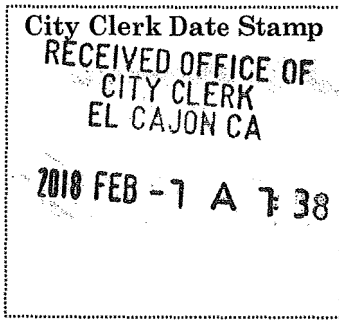

City of El Cajon Agenda Report

MEETING: 2/13/18

ITEM NO: 8.1



TO: Mayor Wells, Mayor Pro Tem Kendrick and Councilmembers Goble and Kalasho

FROM: Councilmember McClellan

SUBJECT: Council Activities Report

RECOMMENDATION: That the City Council accept and file the following report of Council/Mayor activities attended during the current agenda period.

BACKGROUND:

Government Code Section 53232.3(d) requires members of a legislative body to provide brief reports on meetings attended at the expense of the local agency at the next regular meeting of the legislative body.

REPORT:

Since the last City Council meeting, I have attended the following events on behalf of the City of El Cajon:

- February 5, 2018 - Citizen of the Year Luncheon
- February 8, 2018 - Chuck Hansen's Celebration of Life
- February 13, 2018 - City Council Meeting(s)

I will be happy to answer any questions you may have.

SUBMITTED BY,

**Bob McClellan
Councilmember**

City Clerk Date Stamp

RECEIVED OFFICE OF
CITY CLERK
EL CAJON CA

2018 FEB -6 P 2:09

City of El Cajon Agenda Report

MEETING: 2/13/18

ITEM NO: 9.1



TO: Mayor Wells, Mayor Pro Tem Kendrick and
Councilmembers Goble and McClellan

FROM: Councilmember Kalasho

SUBJECT: Council Activities Report

RECOMMENDATION: That the City Council accept and file the following report of Council/Mayor activities attended during the current agenda period.

BACKGROUND:

Government Code Section 53232.3(d) requires members of a legislative body to provide brief reports on meetings attended at the expense of the local agency at the next regular meeting of the legislative body.

REPORT:

Since the last City Council meeting, I have attended the following events on behalf of the City of El Cajon:

- January 18, 2018 - ECEDC Meeting
- January 24, 2018 - Albondigas (East County Chapter)
- January 25, 2018 - Congressman Duncan Hunter Meeting - Jimmy's Restaurant
- January 26, 2018 - Conference Call - State Assembly Randy Voepel's Office
- February 8, 2018 - Best of East County Event
- February 13, 2018 - City Council Meeting(s)

I will be happy to answer any questions you may have.

SUBMITTED BY,

Ben Kalasho

Ben Kalasho
Councilmember

A handwritten signature in black ink, appearing to be "Ben Kalasho", written over a horizontal line.

City Clerk Date Stamp

RECEIVED OFFICE OF
CITY CLERK
EL CAJON CA

2018 JAN 29 P 2:05

City of El Cajon Agenda Report

MEETING: 2/13/18

ITEM NO: 9.2



TO: Mayor Wells, Mayor Pro Tem Kendrick,
Councilmembers Goble and McClellan

FROM: Councilmember Kalasho

SUBJECT: Proclamation Honoring the El Cajon Police Department

RECOMMENDATION: That the City Council place on its next agenda a proclamation honoring our Police Department for its outstanding service to this community.

BACKGROUND: In reflecting on the local, national and international coverage by a multitude of media outlets and social media(s) regarding the Urgency Food Sharing Ordinance, I believe that as a City Council, we should show our commitment to those men/women from the El Cajon Police Department who have had to deal with the ridiculousness of misleading headlines, editorial hit pieces and prejudicial attacks on their integrity. I know this is a part of their job, unfortunately, it's the world we live in. However, as I watched video after video of their commitment from that day, their dialogue as compared to the bad behavior and demeanor of the violators, I was proud of their steadiness and acumen.

I recommend that the City Council place on its next agenda a proclamation honoring our Police Department for their outstanding service to this community.

FISCAL IMPACT:

Not applicable.

PREPARED BY:

Ben Kalasho

Ben Kalasho
COUNCILMEMBER



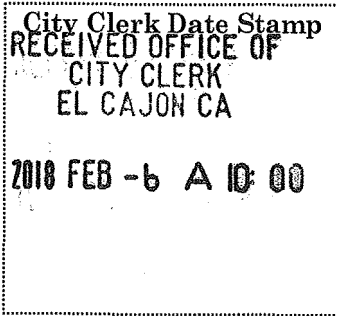

City of El Cajon Agenda Report

MEETING: 2/13/18

ITEM NO: 10.1

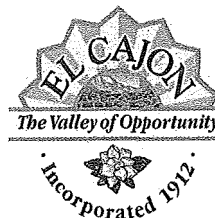

TO: Mayor Wells, Mayor Pro Tem Kendrick, and Councilmembers Kalasho and McClellan

FROM: Councilmember Goble

SUBJECT: Council Activities Report

RECOMMENDATION: That the City Council accept and file the following report of Council/Mayor activities attended during the current agenda period.

BACKGROUND:

Government Code Section 53232.3(d) requires members of a legislative body to provide brief reports on meetings attended at the expense of the local agency at the next regular meeting of the legislative body.

REPORT:

Since the last City Council meeting, I have attended the following events on behalf of the City of El Cajon:

- January 23, 2018 - East County Chamber Gov't Affairs Committee
- January 24, 2018 - Meeting w/Supervisor Jacob, St Paul's, Alpha Project
- January 30, 2018 - Phone meeting with City Attorney
- January 30, 2018 - Meeting with Mark Lane, Shane Parmely, Roland Slade
- January 31, 2018 - Present Certificate of Appreciation to ECS Accord
- February 2, 2018 - East County Chamber First Friday Breakfast
- February 5, 2018 - El Cajon Citizen of the Year Luncheon
- February 7, 2018 - Meeting with City Manager, Chief of Police
- February 8, 2018 - Chuck Hansen Memorial Service
- February 8, 2018 - Best of East County Awards Reception
- February 13, 2018 - City Council Meeting(s)

I will be happy to answer any questions you may have.

SUBMITTED BY,

Steve Goble

Steve Goble
Councilmember

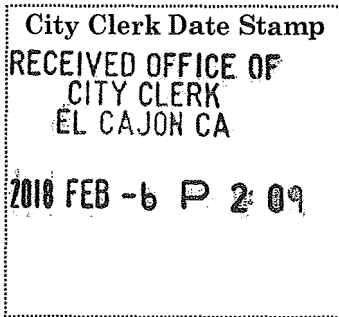

City of El Cajon Agenda Report

MEETING: 2/13/18

ITEM NO: 10.2



TO: Mayor Wells, Mayor Pro Tem Kendrick,
Councilmembers Kalasho and McClellan

FROM: Councilmember Goble

SUBJECT: Enhancements to the City’s Effort Addressing Homelessness

RECOMMENDATION: That the City Council place on a future meeting agenda a discussion, and any relevant action, on the ways to make the public, including people experiencing homelessness, more aware of the help available to people who are homeless, including the City’s own efforts.

BACKGROUND:

Last June, 2017, the Council authorized strategies to help address homelessness in El Cajon. In August, 2017, the Council funded those strategies.

As the strategies have been implemented, the focus of promoted messages, including signage, has been to the potential donor, discouraging cash contributions directly to people experiencing homelessness and requesting those resources be redirected to organizations which provide supportive services to the homeless community.

The focus of less visible, less promoted messages has been on funding a Navigator, rapid rehousing rental assistance, providing reunification funds for The Salvation Army to administer, and more.

I believe now is a good time for “Phase II” of this program and reverse the messages. That is, I’m recommending 1) the promoted, visible messages, included signage, be changed to target individuals experiencing homeless with a positive message for who to call for help (vs “Don’t Support Panhandling”), and 2) the lesser or non-promoted messages on the City’s funding and knowledge of resources in the private sector be made more visible.

I recommend the Council place on the agenda at an upcoming meeting a discussion and possible action to City staff to examine ways to make the public more aware of the help available to those experiencing homeless, including the City’s efforts.

FISCAL IMPACT:

To be discussed.

PREPARED BY:

Steve Goble

Steve Goble
COUNCILMEMBER

RECEIVED OFFICE OF
CITY CLERK
EL CAJON CA
2018 JAN 29 P 12:21

City of El Cajon Agenda Report

MEETING: 02/13/18

ITEM NO: Gen Info A

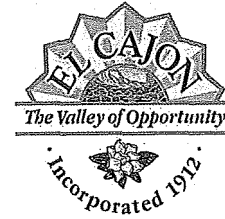

TO: Mayor Wells, Mayor Pro Tem Kendrick,
Councilmembers Goble, Kalasho and McClellan

FROM: Frank Carson, Director of Recreation

SUBJECT: Teen Coalition Status Report

RECOMMENDATION: That the City Council receives and files the information-only Teen Coalition status report.

BACKGROUND: “Engage, educate and empower” continue to be the goals for the City of El Cajon Teen Coalition. Teen Coalition members work with staff liaison, Recreation Services Supervisor Susie Lowe, to learn about leadership and community economics. They are also provided opportunities to engage in community service.

FISCAL 2017-2018 RECRUITMENT:

Applications were actively circulated at El Cajon middle schools, high schools, recreation centers, libraries and local service organizations. Press releases were sent to local news media outlets and mass emails were sent to teens that were or have participated in the Recreation Department’s activities and/or instructional classes. Information was posted on social media outlets and the application was made available on the City’s website.

Eighteen applications were received and an interview panel consisting of two Recreation staff selected all eighteen to serve as members. Coalition members were selected based on their demonstrated level of commitment and their desire to develop leadership skills. Of those selected for 2017/2018, six are returning members to the Teen Coalition and twelve are new members:

Alvin Mwangi, Chair	Lili Bell, (Past Chair)	Blake Ballew (new)
Eric Ayala, Vice Chair	Precious Ulel, (Past Vice-Chair)	Dahila Blake (new)
Aya Adelmahdi, Secretary	Estivan Ayaramia (new)	McKaylay Fish (new)
Dylan Garcia, Treasurer	Anji Butrus (new)	Vianca Margo (new)
Laith Michael (new)	Sama Michael (new)	Lundyn Murphy (new)
Sage Ollison (new)	Kate Pamituan (new)	Lamont Taylor (new)

February 13, 2018

Subject: Teen Coalition Status Report

Page 2

.....
FISCAL YEAR CALENDAR:

In addition to special events, the Teen Coalition will meet each month at Renette Park Community Center. Calendar of events include:

- Team building activity and tours
- HauntFest
- Witness "government in action" at the February City Council meeting
- Seminars and training concerning the local economy
- City of El Cajon's Arbor Day Celebration
- El Cajon Library's Fiesta Celebration
- America on Main Street
- August Movies in the Park at Renette
- Concluding the year with a community service project (May through August).

The City of El Cajon Teen Coalition will also continue to sponsor the annual "Youth of the Year" award, as it further helps put a spotlight on those youth who go above and beyond in serving their community.

FISCAL YEAR 2017-2018 IMPACT STATEMENTS:

All members of the Teen Coalition exhibit a passion for volunteering, community involvement and development of leadership skills. The Teen Coalition application requested remarks regarding perceived critical issues facing teens in the community. Providing safe teen activities as well as developing an information link for Teen Volunteer Groups and job skill training is a focus of this year's Teen Coalition. In response, the Teen Coalition is developing activities and projects that would address these critical issues.

FISCAL IMPACT: Current fiscal year budgeted amount of \$1,200 for training, meetings, events, and projects.

PREPARED BY:



Adam Tronerud
Recreation Services
Manager

REVIEWED BY:



Frank Carson
Director of Recreation

APPROVED BY:



Douglas Williford
CITY MANAGER

City of El Cajon Agenda Report

MEETING: Feb. 13, 2018

ITEM NO: 100

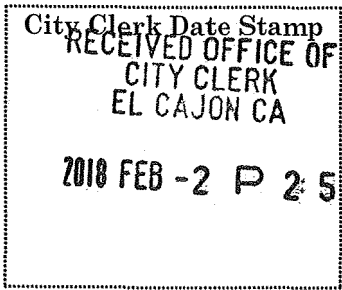
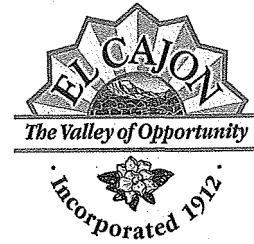

TO: Mayor Wells, Mayor Pro Tem Kendrick,
Councilmembers Goble, Kalasho and McClellan

FROM: Angela Aguirre, City Clerk

SUBJECT: INTERVIEWS FOR COMMISSION VACANCIES

RECOMMENDATION: That the City Council conducts interviews for one (1) seat on the Personnel Commission and one (1) seat on the Planning Commission, and appoints applicants to serve appropriate terms.

BACKGROUND: On December 12, 2017, the City Council approved the application period for seats on various City Commissions. Press releases were distributed to local media about the vacancies. Additionally, applications were available on the City's website and in the City Clerk's office. Applications received were provided to the City Council in their agenda packets for consideration. Applicants were advised of the opportunity to make a two-minute presentation during the interviews, followed by a question and answer period by Council.

PERSONNEL COMMISSION

One Commissioner: (1) Term expiration – Richard Nasif

- One (1), four-year term to expire January 31, 2022
- To be appointed by the City Council from a list of 3 persons nominated by employees in the Classified Service, except when an incumbent is to be re-nominated, then 1 name may be submitted.

Applicant:

1. Richard Nasif (Incumbent)

PLANNING COMMISSION

One Commissioner: (1) Term expiration – Anthony Sottile

- One (1), four-year term to expire January 31, 2022
- Appoint one (1) member, a resident of the City.

Applicants:

1. Zachary Bunshaft
2. Humbert Cabrera
3. Pavel Consuegra
4. Vickie Fageol
5. Sherri Johnston
6. Robert Pennoyer
7. James Queenan
8. Janet Reaume
9. Anthony Sottile (Incumbent)

VETERANS' COMMISSION

No applications were received. Staff recommends that applications be accepted on a continuous basis until position is filled.

Members of the above-mentioned Commissions are required to participate in Ethics Training, and file a Statement of Economic Interests (Form 700) according to the provisions of the Political Reform Act, the Fair Political Practices Commission, and the City's Conflict of Interest Code.

FISCAL IMPACT: Members of the Planning and Personnel Commissions are compensated for meetings attended. Members of the Veterans' Commission serve on a voluntary basis and are not compensated.

PREPARED BY:

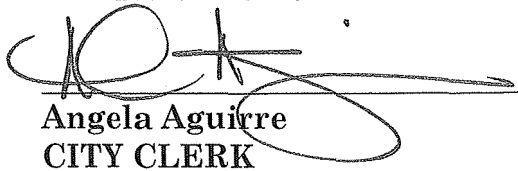
Angela Aguirre
CITY CLERK

APPROVED BY:

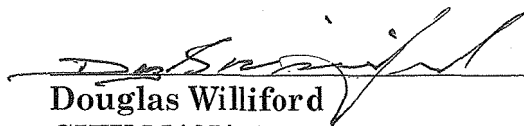
Douglas Williford
CITY MANAGER

Applications may be viewed in the City Clerk's Office during regular office hours: Monday – Thursday, 7:30 a.m. to 5:30 p.m., and alternate Friday, 8:00 a.m. to 5:00 p.m.

City Clerk's Office
City Hall
200 Civic Center Way
El Cajon, CA 92020

(619) 441-1763